

**1-7000 SERIES
TANDEM PLUG
CONTROL VALVES**

1-7000 SERIES TANDEM PLUG CONTROL VALVES



PARCOL 1-7000 series control valves are especially designed for high pressure applications on high differential pressure water or steam condensate service. They are intended primarily for power plant installations where can be used for the most critical services such as high pressure steam line drain, continuous blow down, lines warm-up, cooling water stop or control for desuperheating systems. Linear or angle type drop-forged steel body with peculiar design of bonnet assure an heavy, compact and reliable construction. The particular design of trim with intermediate, cage guided, double plug, allows to separate sealing surfaces from the modulating ones, warranting, combined with an appropriate material selection, a perfect and reliable sealing.

A wide range of multi-step trim combinations make this valve suitable for modulating and on/off service with extremely high pressure drops where perfect and reliable seal is required.

Where erosion and cavitation is a problem, single or multiple concentric cages with special drilling are available.

1-7000 valves are usually equipped with Parcol 1-X-290 single or double diaphragm multi spring pneumatic actuators. Other electric or hydraulic actuators can be provided on request.

MAIN FEATURES

BODY

- type: single port, straight way or angle
- construction: forged
- materials: ASME materials
- sizes: DN 1" through 3"
- connections: ANSI flanged
Butt welding ANSI B16.25
Socket welding up to NPS 2"
- ratings: according to ASME B16.34 materials ANSI 2500 for all sizes

FLOW DIRECTION

Flow to close (over seal plug)

BONNET

- Type: flanged
- Construction: forged
- Materials: same as body
- Low Emission certified packings are available on request

TRIM TYPE

- Double plug operating in tandem (control and seal plug) with multicage labyrinth

CONTROL PLUG

- Sizes: diameters from 11 to 30 mm as reported in Cv tables
- Type: cage guided
- Materials: see materials of construction table

SEAL PLUG

- Type: unbalanced to produce high seating force and integrated with stem
- Materials: see materials of construction table

SEAT

- Mounting: free fitted in the body without screwing or forcing guided by cage
body and seat coupling sealed by means of a self sealing gasket
- Materials: see materials of construction table

CAGES

- Construction: forged and drilled cylinders tightened between body and bonnet.
- Materials: see materials of construction table

STEM PACKINGS

- GRF: Pure flexible graphite packing without practical temperature limitation (max 450°C in presence of oxidizing fluids)

LEAKAGE CLASSES

In accordance with A Grade of EN 12266-1 standard (corresponding to DIN 3230 BN1 or BO1); normally used for On-Off valves.

NUMBERING SYSTEM

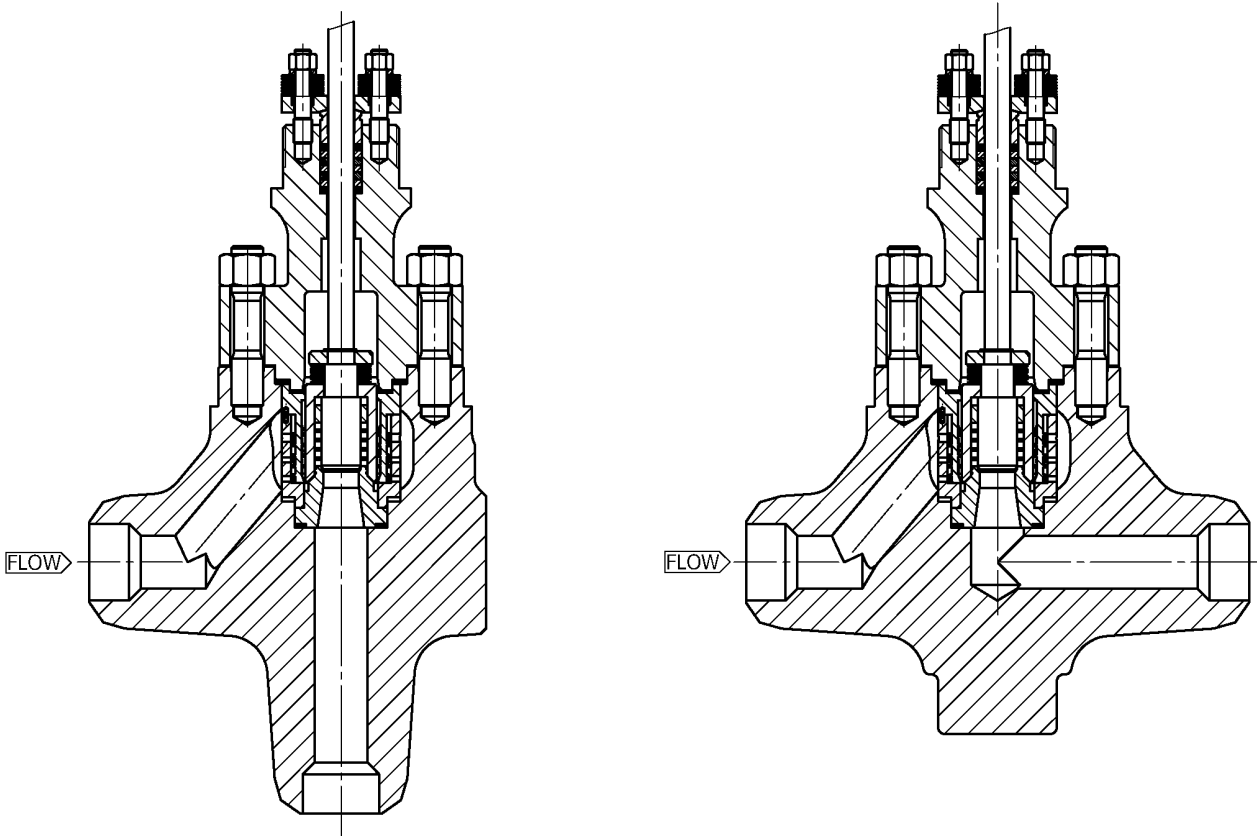

1 - 7 X 2 1

BODY TYPE	
6	angle
9	straight

FLOW DISTRIBUTION

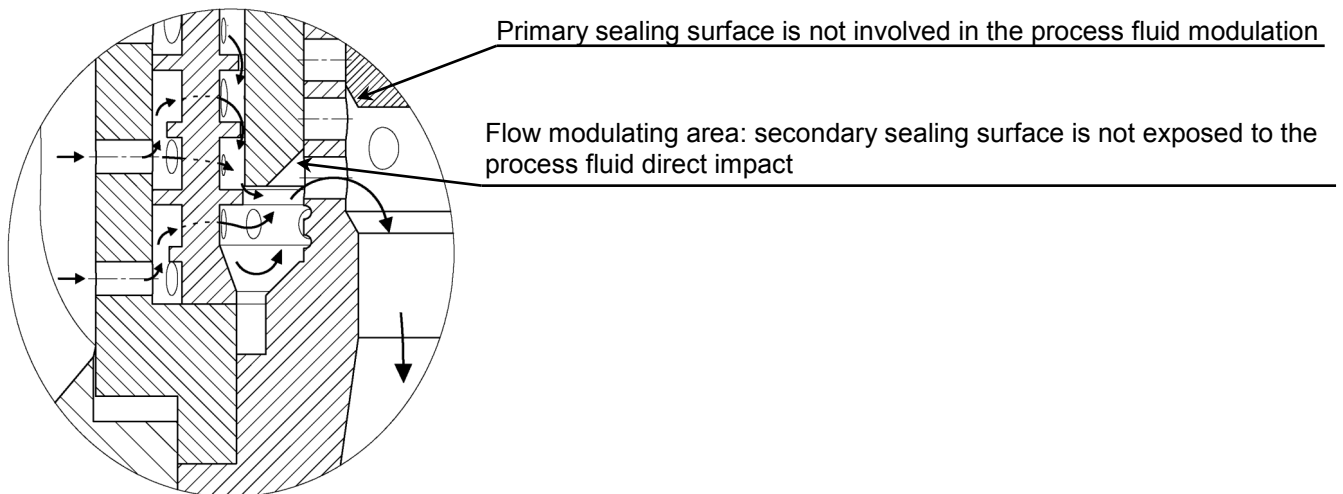

FLOW COEFFICIENT $C_v^{(1)}$, PRESSURE RECOVERY FACTOR F_L , PRESSURE DIFFERENTIAL RATIO FACTOR x_T

DN in.	Seat ϕ mm	Travel mm	Cv max 100%	Flow characteristic: LINEAR										
				TRAVEL % ⁽²⁾⁽³⁾										
				5%	10%	20%	30%	40%	50%	60%	70%	80%	90%	100%
Pressure recovery factor F_L				0.946	0.946	0.946	0.946	0.948	0.950	0.952	0.955	0.959	0.962	0.964
Pressure diff. ratio factor x_T				0.806	0.806	0.806	0.806	0.806	0.812	0.816	0.822	0.827	0.833	0.836
1 ÷ 3	8	25	1.02	-	0.0473	0.0538	0.17	0.361	0.528	0.677	0.8	0.897	0.975	1.02
			1.61	-	0.0477	0.0608	0.252	0.565	0.817	1.06	1.28	1.44	1.55	1.61
1	14	34	2.68	-	0.11	0.128	0.512	1.09	1.58	1.99	2.26	2.46	2.61	2.68
			3.17	-	0.111	0.135	0.607	1.31	1.9	2.36	2.69	2.93	3.1	3.17
1.1/2 ÷ 3	14	34	3.15	-	0.11	0.128	0.515	1.12	1.66	2.16	2.52	2.81	3.04	3.15
			4.05	-	0.111	0.135	0.611	1.36	2.05	2.66	3.17	3.58	3.91	4.05
	20	34	6.39	-	0.166	0.197	1.02	2.17	3.16	4.18	4.97	5.61	6.15	6.39
			9.09	-	0.166	0.208	1.42	3.08	4.38	5.78	7.04	8.06	8.79	9.09
2 ÷ 3	27	45	12.5	0.221	0.253	0.289	2.01	4.08	6	7.81	9.66	10.8	12.1	12.5
			16.7	0.221	0.253	0.299	2.64	5.46	7.84	10.3	12.9	14.6	16.2	16.7

DN in.	Seat ϕ mm	Travel mm	Cv max 100%	Flow characteristic: EQUAL PERCENTAGE										
				TRAVEL % ⁽²⁾⁽³⁾										
				5%	10%	20%	30%	40%	50%	60%	70%	80%	90%	100%
Pressure recovery factor F_L				0.946	0.946	0.946	0.946	0.947	0.948	0.950	0.953	0.956	0.961	0.964
Pressure diff ratio factor x_T				0.806	0.806	0.806	0.806	0.807	0.808	0.812	0.817	0.823	0.831	0.836
1 ÷ 3	8	25	0.955	-	0.0468	0.0511	0.122	0.231	0.363	0.527	0.684	0.789	0.883	0.955
			1.59	-	0.0472	0.053	0.159	0.337	0.542	0.81	1.07	1.3	1.48	1.59
1	14	34	2.57	-	0.11	0.122	0.305	0.587	0.896	1.35	1.76	2.13	2.43	2.57
			3.08	-	0.11	0.123	0.462	0.991	1.46	1.98	2.4	2.74	3.03	3.08
1.1/2 ÷ 3	14	34	2.98	-	0.11	0.122	0.306	0.591	0.91	1.4	1.88	2.34	2.77	2.98
			3.87	-	0.11	0.123	0.464	1.01	1.53	2.15	2.73	3.26	3.77	3.87
	20	34	6.13	-	0.164	0.188	0.791	1.55	2.38	3.4	4.28	5.13	5.83	6.13
			8.3	-	0.164	0.192	0.871	1.83	2.9	4.2	5.5	6.83	7.88	8.3
2 ÷ 3	27	45	12.5	0.221	0.252	0.283	1.47	2.89	4.29	5.97	7.85	9.98	11.8	12.5
			14.5	0.221	0.252	0.285	1.52	2.99	4.65	6.51	8.76	11.3	13.6	14.5

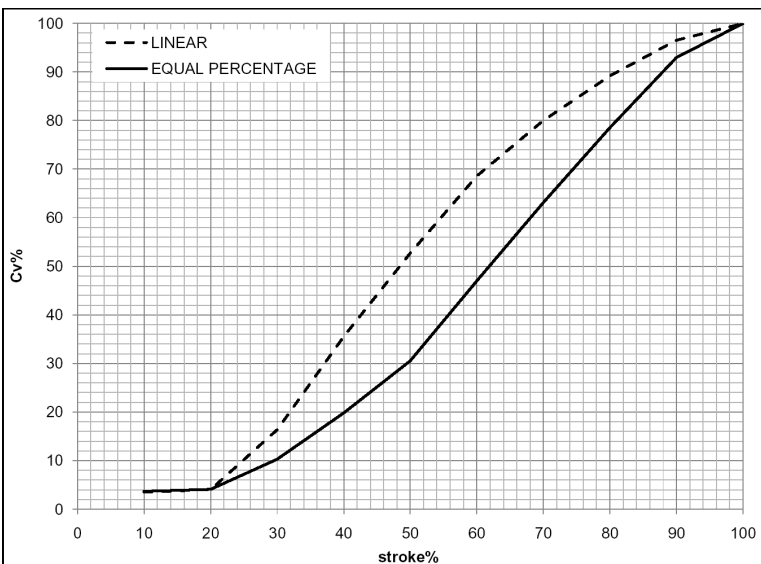

Port 14 mm flow characteristics

(1) C_v are expressed in U.S. gallons/min. of water with $\Delta p=1$ psi
 (2) Rangeability can be calculated as $C_v \text{ max}/C_v \text{ 10\%}$
 (3) Tolerances according to IEC 60534-2-4

VALVE ASSEMBLY

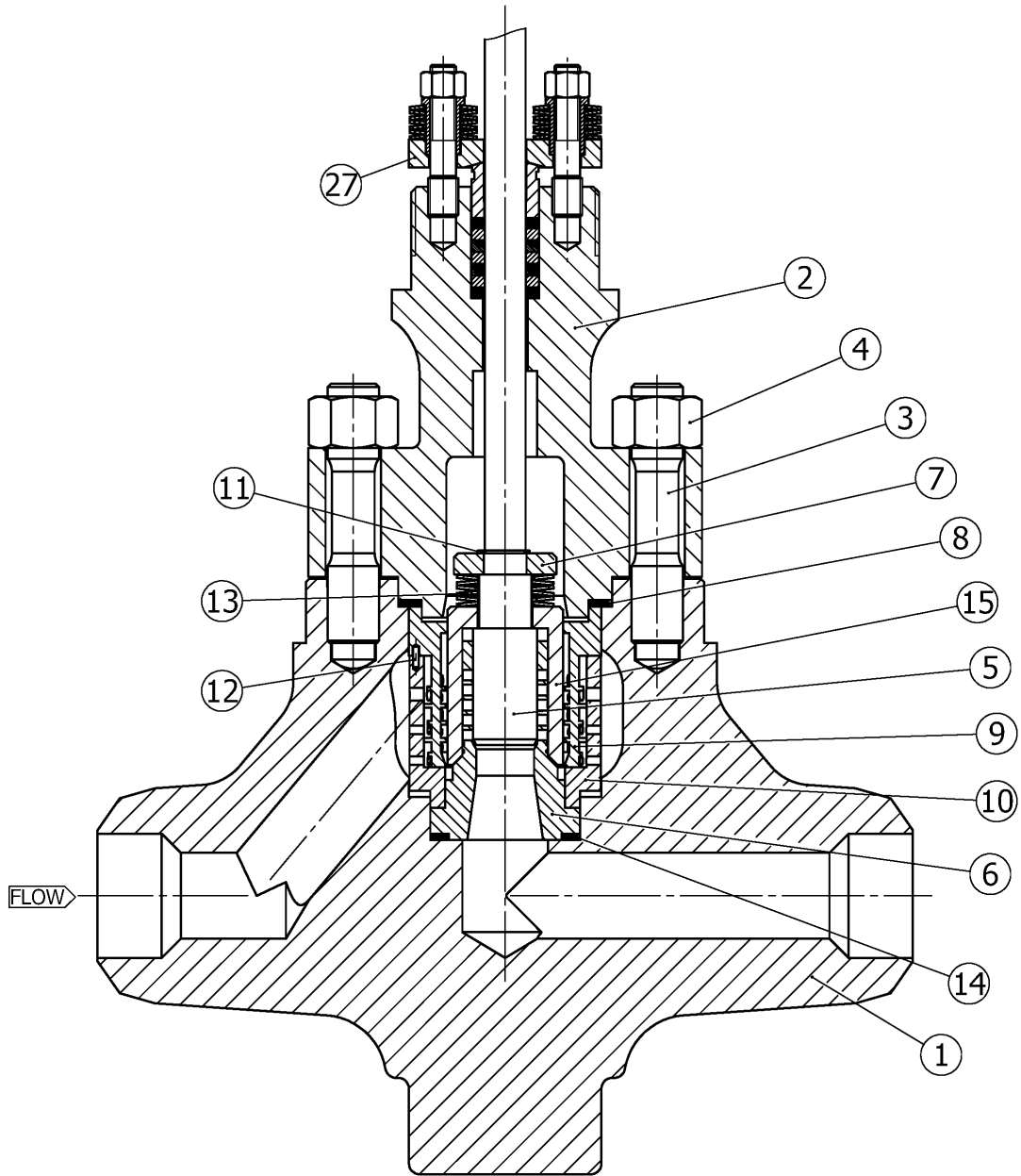

ITEM	PART NAME
1	BODY
2	BONNET
3	BODY STUD
4	NUT
5	PLUG
6	SEAT
7	LOCK NUT
8	GASKET
9	CAGE
10	CAGE
11	SEEGER
12	PIN
13	DISC SPRING
14	GASKET
15	CONTROL PLUG
27	PACKING

MATERIALS OF CONSTRUCTION

BASIC CLASS		A	D			V	
ITEM	PART NAME	TEMPERATURE RANGE ⁽¹⁾					
		-29 ⁽²⁾ ÷ +427°C	-29 ⁽³⁾ ÷ +450°C	>+450 ÷ +566°C	-29 ⁽³⁾ ÷ +450°C	>+450 ÷ +566°C	
1	BODY	SA-105 or SA-350 LF2	SA-182 F22 Cl.3		SA-182 F91		
2	BONNET						
3	BODY STUD	SA 193 B7	SA 193 B16		SA 479 XM-19		
4	NUT	SA 194 Gr.4	SA 194 Gr.8				
5	PLUG	AISI 440B					
6	SEAT	AISI 440B					
7	LOCK NUT	AISI 304					
8-14	GASKET	AISI 321 + GRAPHITE					
9-10	CAGE	A 182 F6NM Nitrided					
11	SEEGER	INCONEL X750					
12	PIN	AISI 304					
13	DISC SPRING	INCONEL 718					
15	CONTROL PLUG	SA 654 – 630 H900	SA 654 – 630 H900	INCONEL 718	SA 654 – 630 H900	INCONEL 718	
27	PACKING	see "PACKING FOR CONTROL VALVES" Parcol bulletin					

MAX DIFFERENTIAL PRESSURE ACROSS THE VALVE Δp - bar

DN in.	Seat \varnothing mm	Parcol Actuator Type ⁽⁴⁾	AIR TO OPEN (reverse)			AIR TO CLOSE (direct)		
			Spring range psi	Supply psi	shut-off Δp bar	Spring range psi	Supply psi	shut-off Δp bar
1 ÷ 3	8	1-X-290 D46	32 ÷ 47	60	370	16 ÷ 31	60	250
1.1/2 ÷ 3	14	1-X-290 D46	24 ÷ 44	60	180	7 ÷ 28	60	150
	14	1-X-290 D63	28 ÷ 43	60	340	13 ÷ 28	60	360
	20	1-X-290 D46	24 ÷ 44	60	180	7 ÷ 28	60	150
	20	1-X-290 D63	28 ÷ 43	60	340	13 ÷ 28	60	360
2 ÷ 3	27	1-X-290 D63	22 ÷ 41	60	258	7 ÷ 26	60	190
	27	1-X-290 D63D	22 ÷ 41	60	430	7 ÷ 26	60	430

(1) Max operating temperature for continuous service: 400°C

(2) When PED (97/23/CE) is required: - 20°C

(3) When PED (97/23/CE) is required: 0°C

(4) See Parcol 1-X-290 product bulletin, for D63D please contact technical department

OVERALL DIMENSIONS (mm) AND WEIGHTS (kg)

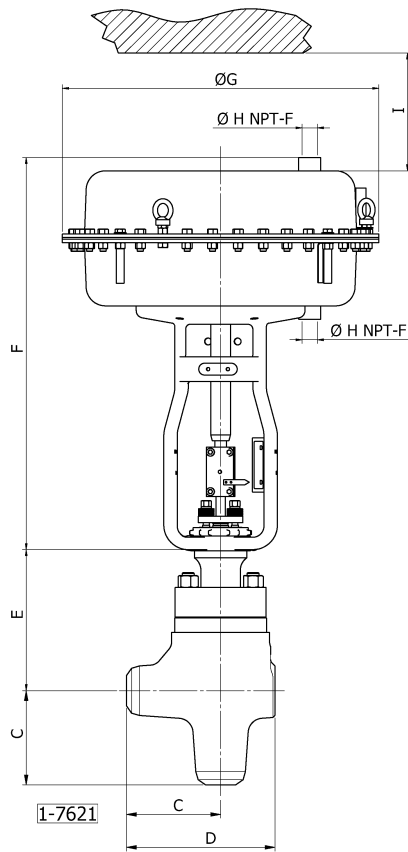
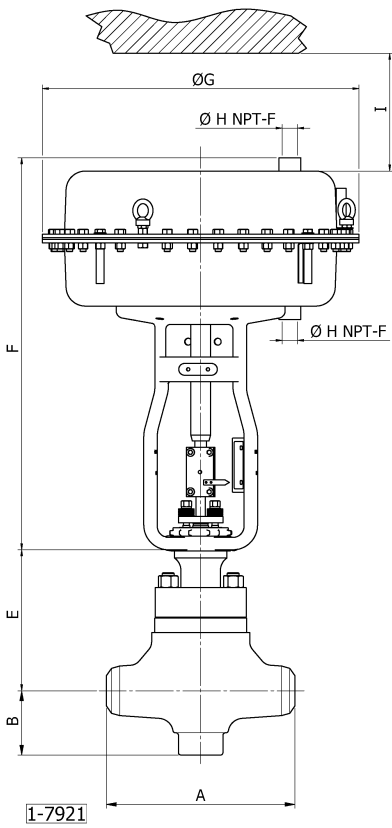

provided with 1-X-290 series multispring diaphragm actuators type D46 or D63

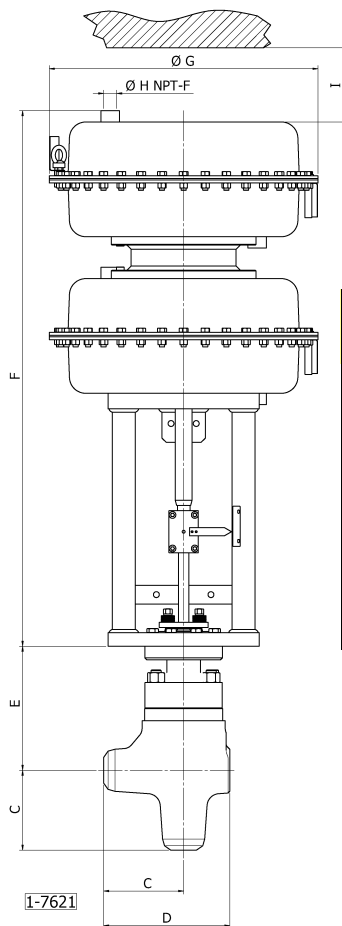
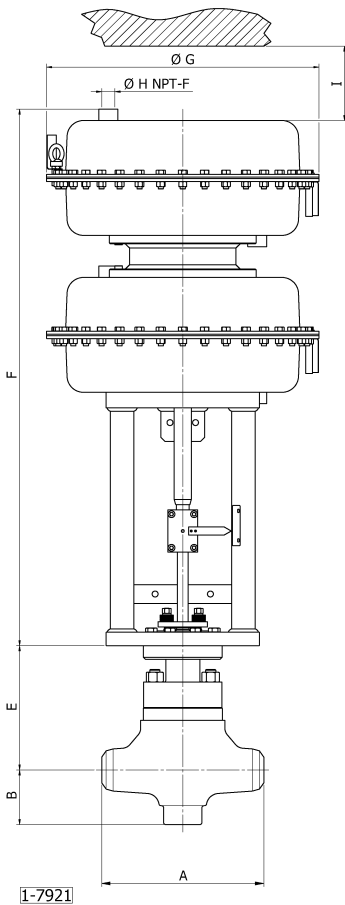

provided with 1-X-290 series multispring double diaphragm actuators type D63D

VALVE TYPE	1-7921			1-7621		
	D46	D63	D63D	D46	D63	D63D
A	381			-		
B	130			-		
C	-			190		
D	-			300		
E	285		317	285	317	
F	644	796	1278	644	796	1278
G	465	640		465	640	
H	1"					
Ø I	200	250		200	250	
weight	142	208	375	142	208	375



PARCOL S.p.A. Via Isonzo, 2 - 20010 CANEGRATE (MI) - ITALY
Telephone: +39 0331 413.111 - Fax: +39 0331 404.215
E-mail: sales@parcol.com - <http://www.parcol.com>