

**1-X-210 SERIES  
DIAPHRAGM  
PNEUMATIC  
ACTUATORS**



# 1-X-210 SERIES DIAPHRAGM PNEUMATIC ACTUATORS



Fig. 1 - Model 1-X-211 (type 600) reverse-acting actuator

1-X-210 Series pneumatic diaphragm actuators are manufactured by PARCOL to suitably operate control valves both for throttling service and on-off service. The thrust is supplied by a rubber, air-loaded diaphragm and, in the opposite direction, by an helical spring.

About the whole PARCOL production of globe, angle and butterfly valves can be fitted by a 1-X-210 series actuator.

Standard model can be delivered either as a direct-acting-actuator (model 1-X-211) or as a reverse acting actuator (model 1-X-212).

## MAIN FEATURES (standard model)

### DIAPHRAGM CASE

Two formed steel cases (upper and lower) tighten the diaphragm edge to get an air-proof sealing.

### YOKE

All direct-acting-actuator yokes are one-piece castings. Reverse-acting-actuator yokes are two-piece castings joined by a flange in type 600; all the other types have a screwed joint and the lower piece is just the yoke of the corresponding direct-acting-actuator.

Standard material is grey cast-iron, on request we can deliver also carbon steel yokes A216WCB or A352LCB (low temperature service).

### DIAPHRAGM

Diaphragm is molded neoprene with a cloth fabric insert. It has an excellent resistance to aging, chemicals and to continuous deformations under load.

The particular design provides a remarkably constant efficiency throughout the travel (see table of net stem thrust).

### RATING T/P

Maximum operating pressure = 3.5 bar (50 psi). Over this pressure limit internal parts of actuator can be permanently deformed.

Case and its joints can withstand a pressure of 10 bar at least without significant permanent deformations (PED certification: PS = 6 bar).

Bursting pressure = over 30 bar.

**DIAPHRAGM PLATE**

The diaphragm plate consists of a heavy section steel plate formed to diaphragm shape.

**SPRING**

The spring is made of a high strength, nickel-silicon-chromium steel and is protected by a corrosion resistant coating.

A suitable spring can be delivered for each listed combination of actuator type, signal range and stroke.

Spring is top and bottom guided by two steel disks.

Springs used are the same for direct and reverse acting types.

**SPRING ADJUSTING SCREW**

The spring adjusting screw is of hardened steel and is threaded on actuator yoke in the direct-acting type and on the stem in the reverse type.

In the direct-acting type, the spring adjusting screw acts as a stem guide by means of a bushing fitted inside.

In the reverse type, the spring adjusting screw moves together with the stem and is guided from the outside by means of a stainless steel bushing fitted inside the actuator yoke.

**STEM**

Stem is made of AISI 316 stainless steel. Guiding (direct-acting type) or sealing (reverse-acting type) surfaces are ground and rolled. Stem is screwed into a bushing fastened on the diaphragm plate. A screw prevents self-disengagement of the two parts.

**CONNECTIONS**

Connections for compressed air are 1/4" NPT ANSI B 2.1 threaded (1/2" NPT on request).

Air is exhausted through a special plug which prevents infiltration of liquids.



Fig. 2 - Direct-acting actuators fitted with top handwheel

EFFECTIVE STEM THRUST - N/psi																		Diaphragm position	
Type	250			310			390			450			600						
Stroke mm Supply	17	17	25	17	25	34	45	17	25	34	45	60	25	34	45	60	76		
7 ÷ 9 psi	155	255	240	420	415	400	390	635	620	605	590	570	1100	1090	1080	1070	1060	"B"	
24 ÷ 40 psi	160	280	260	440	435	430	420	655	645	635	620	600	1140	1130	1120	1110	1100		
0 ÷ 9 psi	165	260	280	440	450	455	470	655	665	680	700	720	1140	1150	1160	1170	1210	"A"	
13 ÷ 15 psi	170	265	280	450	455	460	470	665	675	685	710	720	1160	1170	1180	1190	1210		

- Values suitable for both direct and reverse action

- Example of calculation:

diaphragm: 250 - closed valve signal: 30 psi

configuration: "B" - actual signal to diaphragm: 35 psi - effective thrust: (35-30) x 160 = 800 N

**MODEL 1-X-211 (direct-acting)**

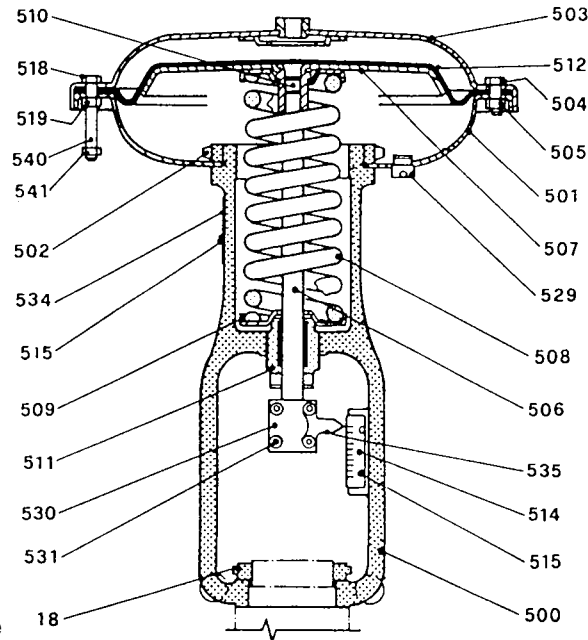

250-310-390-450-600 Type

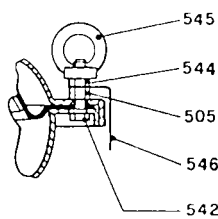

Type 450-600 construction

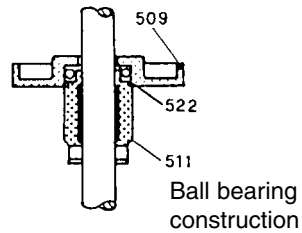

Ball bearing construction

**MATERIALS FOR THE MAIN COMPONENTS**

COMPONENT		MATERIALS AND SERVICE TEMPERATURES			NOTES	
Pos.	Part name	Class A -15° ÷ +60°C	Class B -30° ÷ +60°C	Class C -55° ÷ +60°C		
Diaphragm	18	Clamping nut	Carbon steel	Carbon steel	AISI 316	(1) Can be replaced by A 350 LF-1
	500	Yoke	Grey cast iron	A 216 WCB	A 352 LCB	
	501	Lower diaphragm case	Carbon steel	Carbon steel	Fe37D - UNI 7070	
	502	Diaphragm case locking ring	Carbon steel	Carbon steel	AISI 304 (1)	
	503	Upper diaphragm case	Carbon steel	Carbon steel	Fe37D - UNI 7070	
	504	Diaphragm case screw	8.8 UNI 3740	8.8 UNI 3740	AISI 304	
	505	Diaphragm case nut	A 194-4	A 194-4	AISI 304	
	506	Actuator stem	AISI 304	AISI 304	AISI 304	
	507	Diaphragm plate	Carbon steel	Carbon steel	Fe37D - UNI 7070	
	508	Spring	52 Si Cr Ni 5	52 Si Cr Ni 5	52 Si Cr Ni 5	
	512	Diaphragm	Neoprene	Neoprene	Silicon rubber	
Handwheel	550	Handwheel casing	Grey cast iron	A 216 WCB	A 352 LCB	
	557	Lead screw	AISI 416	AISI 416	17 - 4 PH	
	582	Cranked lever	Carbon steel	Carbon steel	Carbon steel	

**PART LIST**

18	Clamping nut	514	Travel indicator scale	531	Cap screw
500	Yoke	515	Screw	532	Gasket
501	Lower diaphragm case	518	Special cap screw	533	Additional spring barrel
502	Clamping nut	519	Nut	534	Valve serial plate
503	Upper diaphragm case	520	"O" Ring	535	Travel indicator
504	Cap screw	521	"O" Ring	536	Bushing
505	Nut	522	Ball bearing	540	Threading protection
506	Stem	523	Bushing	541	Lock nut
507	Diaphragm plate	524	Ring	542	Screw
508	Actuator spring	525	Washer	544	Lock nut
509	Spring seat	526	Screw	545	Eyebolt
510	Locking screw	527	Nut	546	Eyebolt plate
511	Spring adjustor	529	Vent plug		
512	Diaphragm	530	Stem connector		

Part list references can be used to order spares. Specify always type (250, 310, ecc.), model and action (direct, reverse).

**MODEL 1-X-212 (reverse-acting)**

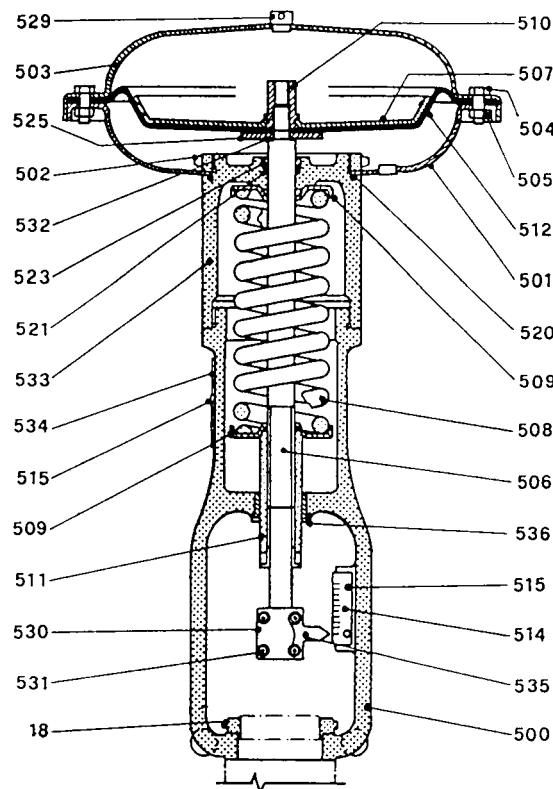

250-310-390-450-600 Type

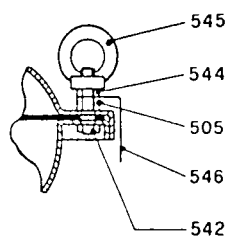

Type 450-600 construction

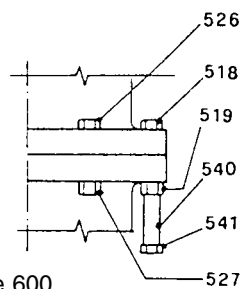

Type 600 construction

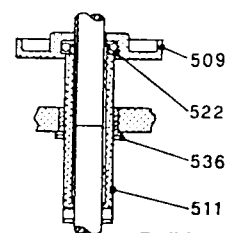

Ball bearing construction

OVERALL DIMENSIONS - mm

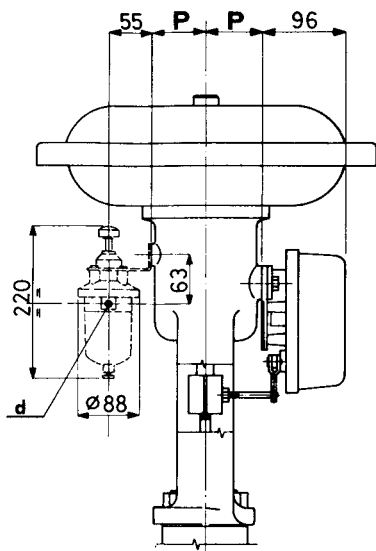
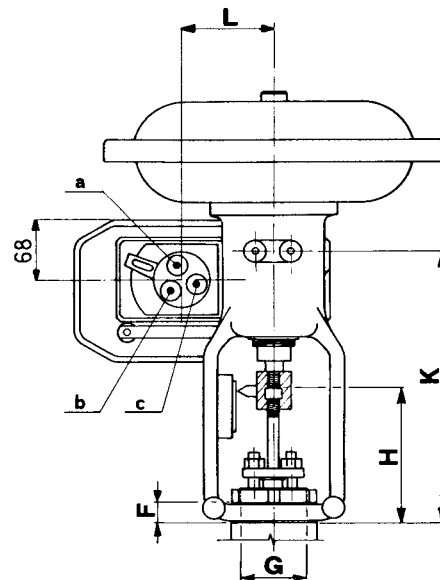
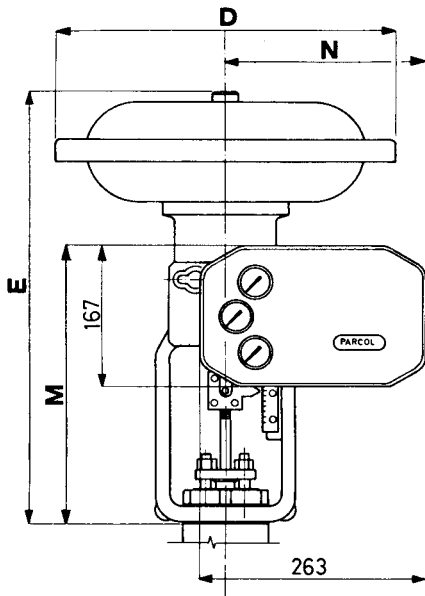

Connections 1/4" NPT female

- a = Outlet
- b = Supply
- c = Signal
- d = Air-set supply

HEIGHT "H" (direct action)						
Stroke mm	17	25	34	45	60	76
Type						
250	120	-	-	-	-	-
310	120	124	-	-	-	-
390	148	152	156	162	-	-
450	157	161	165	171	179	-
600	-	195	199	205	213	220

HEIGHT "H" (reverse action)						
Stroke mm	17	25	34	45	60	76
Type						
250	103	-	-	-	-	-
310	103	99	-	-	-	-
390	131	127	122	117	-	-
450	140	136	131	126	119	-
600	-	170	165	160	153	144

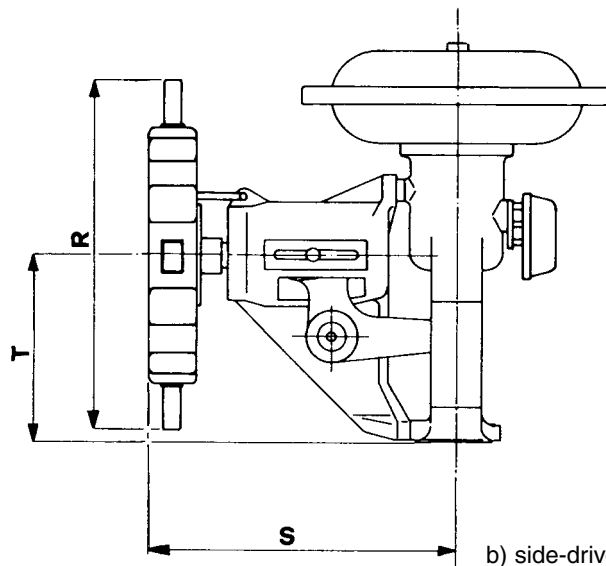

b) side-driven with or without gear box

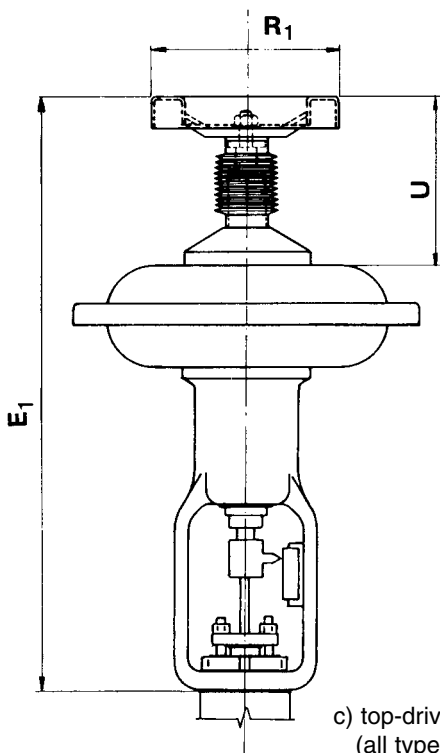

c) top-driven  
(all types, 600 excluded)

Type	Mass - Kg				
	Actuator		Handwheel		
	Dir.	Rev.	Side	Top mounted	
				Dir.	Rev.
<b>250</b>	15	16	10	5	6
<b>310</b>	16	19	10	5	6
<b>390</b>	29	39	19	12,5	15
<b>450</b>	48	63	19	12,5	15
<b>600</b>	100	130	35*	-	-
<b>600 MM</b>	110	140	35*	-	-

\* Gear-box type weights 46 kg

Type	D	E		F	G	K	L	M	N	P	R	S	T	E <sub>1</sub>		R <sub>1</sub>	U	
		Dir.	Rev.											Dir.	Rev.		Dir.	Rev.
<b>250</b>	265	400	460	24	60	265	106	305	230	55	380	300	200	580	640	175	180	210
<b>310</b>	325	410	495	24	60	265	106	305	230	55	380	300	200	595	680	225	185	215
<b>390</b>	400	510	660	24	76	325	106	330	230	67	470	360	240	800	950	300	290	310
<b>450</b>	480	585	750	24	76	335	138	345	265	84	470	365	250	935	1100	400	350	340
<b>600</b>	630	755	955	30	88	425	138	400	265	98	570	455	330	-	-	-	-	-
<b>600 MM</b>	630	870	1070	32	88	530	138	570	265	98	570	470	435	-	-	-	-	-



## HANDWHEELS FOR DIAPHRAGM ACTUATORS

An handwheel, fitted on a pneumatic actuator, enables personnel to operate valve without any respect of the air pressure loading the diaphragm. Such instance is very useful during plant start or safe shut-off or simply every time an air-supply failure occurs. PARCOL can deliver handwheels which can be operated either from top or from side.

Standard materials for main components are listed in table "Materials for main components".

### TOP DRIVEN HANDWHEEL

It can be delivered for mounting on the upper case of all standard PARCOL actuators (except 600 type), both direct-acting (handwheel model 1-X-2113) and reverse-acting (handwheel model 1-X-2123).

Such handwheel has a one-way-only action: makes stem to come out in direct-acting actuators, and to withdraw in reverse-acting actuators. The opposite movement is due solely to the spring thrust; so top handwheel can act as a simple stop device limiting valve stem travel in the spring load direction.

To fully disengage the top driven handwheel installed on direct-acting actuators, it is necessary to take the handwheel at the maximum upward position till the diaphragm compressor (214) subassembly comes in contact with the bottom part of the handwheel body.

To disengage the top driven handwheel installed on reverse acting actuators it is necessary to take the handwheel at the maximum downward position till the handwheel comes in contact with the top part of handwheel body.

In both of the above cases the screwed shaft of handwheel must be locked with suitable nut.

Top-driven handwheel has a very simple design, needs no maintenance and leaves actuator sides free.

### SIDE DRIVEN HANDWHEEL

This device can operate valve stem either to open or to close valve, just by rotating the handwheel in one sense or in the opposite.

Design is based, on a lead-screw / cranked-lever mechanism mounted onto the side of the standard yokes.

Side-mounted device usually rests in a loose position which allows full stroke operation of valve by means of air.



**Fig. 3** - Model 1-X-211 (type 450) direct-acting actuator, equipped with a side-mounted handwheel

Hand operation is switched on automatically turning the handwheel (572) till the cranked-lever (582) starts to move.

Side mounted handwheel can limit travel of valve stem in one of the two directions. To diminish the driving force required by the handle of type 600 actuator, additional reduction gears can be supplied.

**SIDE-DRIVEN HANDWHEEL**

Type 250÷450

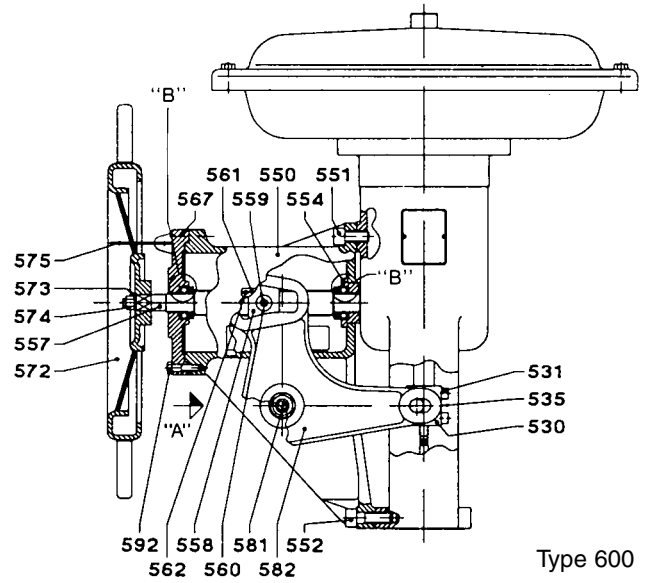
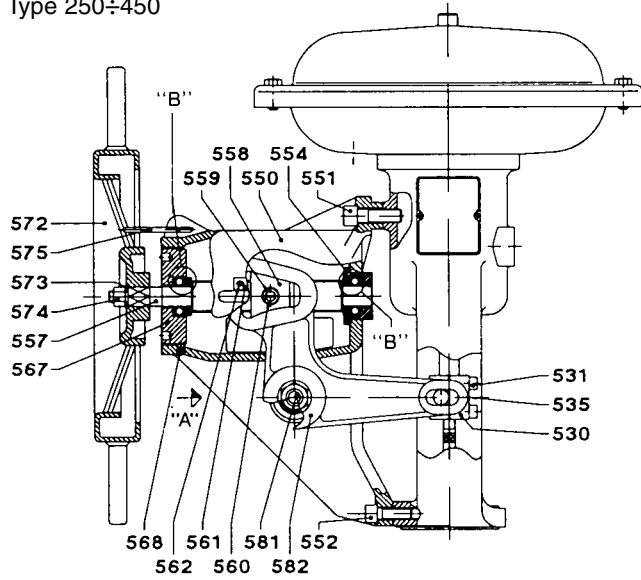

Type 600

Type 600  
with gear box

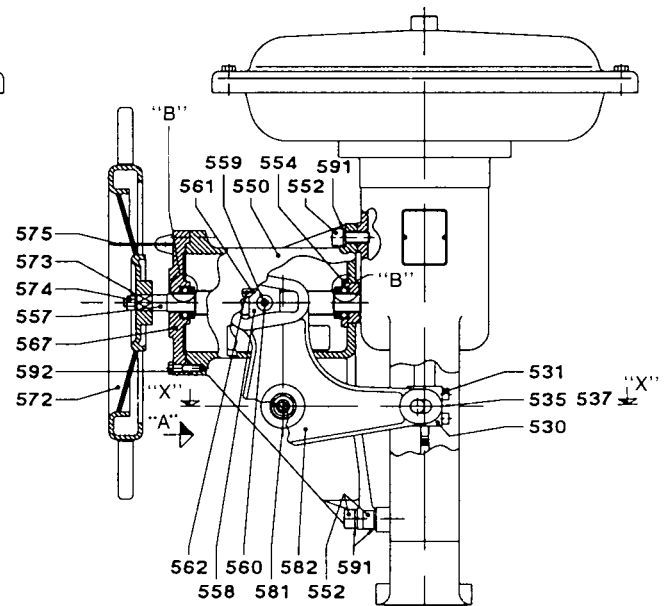
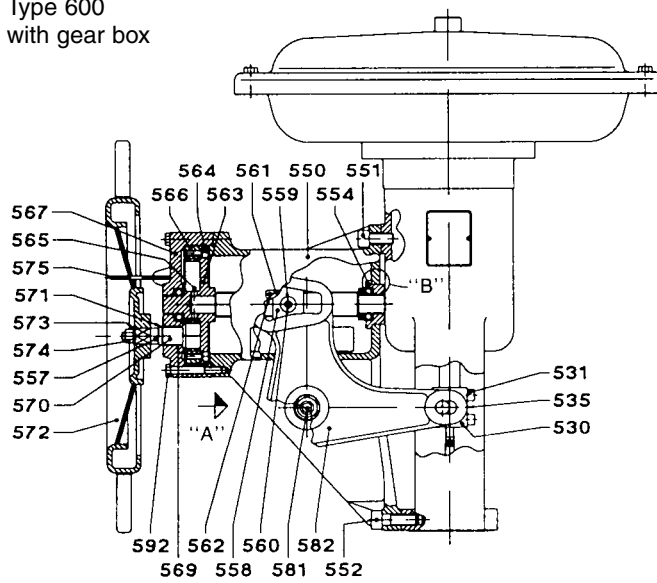

Type 600 MM

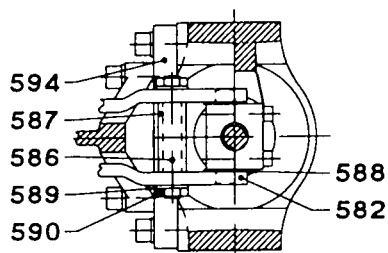

Section "X-X"

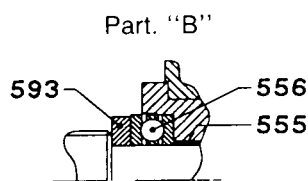

Detail mounting bearing

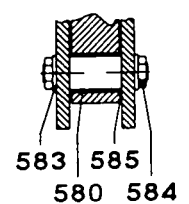

"A" View

**PART LIST**  
(for side-driven handwheel)

530	Stem connector
531	Stem connector screw
535	Travel indicator
537	Screw
550	Handwheel casing
551	Handwheel casing screw
552	Handwheel casing screw
554	Ball bearing housing
555	Guide bushing
556	Ball bearing
557	Lead screw
558	Lead nut
559	Position pointer
560	Nut
561	Position plate
562	Screw
563	Ring gear wheel
564	Screw
565	Coupling pin
566	Ring gear
567	Handwheel casing cover
568	Set screw
569	Bushing
570	Pinion gear
571	Locking ring
572	Handwheel
573	Washer
574	Handwheel locking nut
575	Handwheel stop
580	Lever pin bearing
581	Lever pin
582	Cranked lever
583	Washer
584	Nut
585	Washer
586	Bolt
587	Spacer
588	Bushing
589	Washer
590	Nut
591	Washer
592	Screw
593	Washer
594	Support

**PART LIST**

200	Body
201	Screwed shaft
202	Ball bearing
203	Space ring
204	Stop ring
205	Guide bushing
206	Bellows
207	Screw
208	Handwheel
209	Nut
210	Washer
211	Nut
212	Screw
213	Stop ring
214	Diaphragm plate
215	Elastic pin
216	"OR" ring
217	"CORTECO" ring
223	Clamp (if any)
225	Diaphragm plate connection
226	Screw

**TOP HANDWHEEL (Types 250 ÷ 450)**

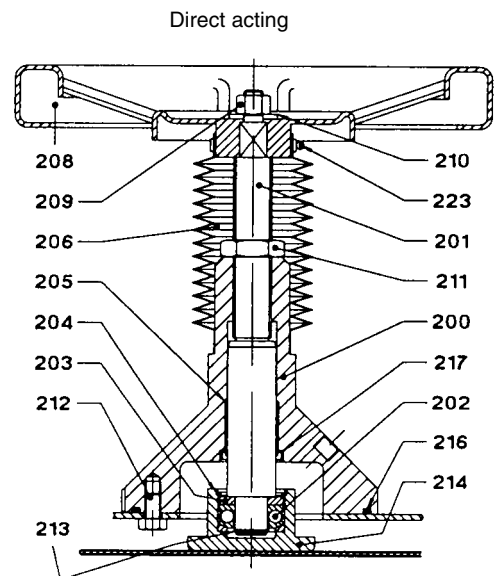

Construction for type	1-X-271	1-X-290	1-X-211
	D39 stroke 76	D39 stroke 34	390
	D46 stroke 90	D46 stroke 45	450

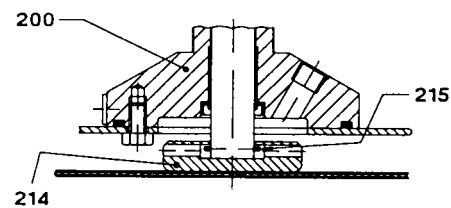

Construction for type	1-X-271	1-X-290	1-X-212
	D25 stroke 45	D25 stroke 17	250
	D33 stroke 76	D33 stroke 25	310

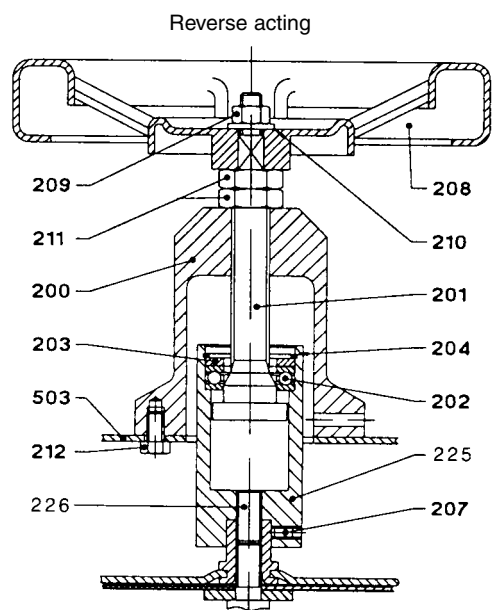



**PARCOL S.p.A.** Via Isonzo, 2 - **20010 CANEGRATE** (MI) - ITALY  
C.C.I.A.A. 554316 - Fiscal code & VAT no. (IT) 00688330158  
Telephone: +39 0331 413 111 - Fax: +39 0331 404 215  
e-mail: [sales@parcol.com](mailto:sales@parcol.com) - <http://www.parcol.com>