



**HYDRAULIC
CONTROL
SYSTEM
Compact**

HYDRAULIC POWER UNIT (HPU)

The hydraulic power unit is provided with a steel tank suitable for outdoor service able to collect the full volume of oil present in the circuit. The tank is equipped with inspection door, breather with filter, 2 level switches, 1 temperature switch, 1 visual level indicator.

Two main motor-pump groups **P1** and **P2**, each one fitted with an electric motor, are provided on the tank; the fixed displacement pump is able to deliver the required flow rate at a pressure of 200 bar.

A filtering/conditioning group composed by fixed displacement pump **P3**, filter with clogging detector (**DPS3**) and exchanger (**R**) with fan piloted by internal thermostat is provided on board.

Functions of the main pumps are :

- n° 1 active pump, to maintain all control valves in closed / open position or under continuous control.
- n° 1 stand-by pump to be activated on alarm signal from low pressure switch mounted on pump common delivery manifold

The pump flow rate is sufficient to ensure the maximum stroke time required in control mode for each valve without involving the accumulator intervention.

Four pressure switches are installed in the common delivery manifold of the motor-pump groups, as follows:

PS1 supplies the "low oil pressure signal"

PS2 supplies the "minimum oil pressure signal" (i.e. plant out of commission).

PS3 stops the active pump

PS4 starts the active pump

One accumulator **A1**, constantly inserted on the delivery manifold, is installed on the hydraulic power unit to grant trouble-free change-over from a motor/pump group to the other one.

The overflow valve **VS3** controls the oil pressure in the primary circuit.

Two sealed maximum pressure safety valves **VS1** and **VS2** are mounted on pump deliveries.

A double filter **F** provided with electric clogging detectors **DPS1-DPS2** is installed at power unit outlet.

The hydraulic power unit is provided with two terminal boxes: the first one is intended for instrument cables, the second one for the electric motors.

One accumulator (20 litres) assists the pumps for control and quick actions of the connected valves.

Solenoid valves for emergency actions and proportional valves for control mode are installed on the hydraulic cylinder.

Options:

- Heating system
- Accumulator (10 litres)
- Pressure relief valve for accumulator with PED certification
- Hand pump
- First filling oil
- Charging and testing unit for accumulators
- Cabinet with PLC for HPU management (no solenoid power supply)
- Servocylinders with built-in solenoid and proportional valves.

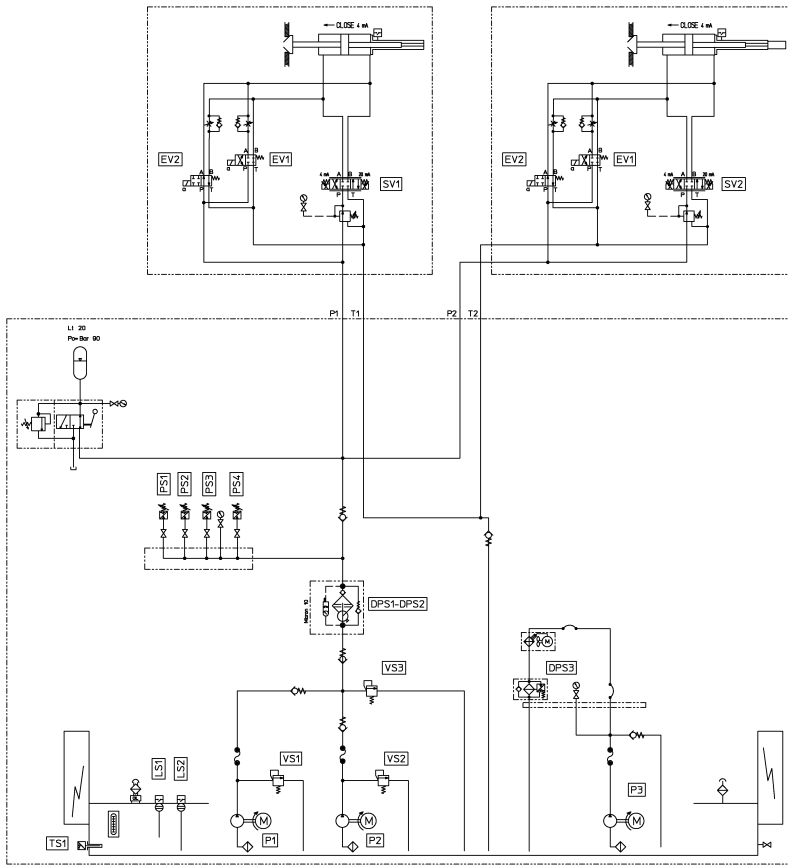

HYDRAULIC DIAGRAM



CONTROL HYDRAULIC ACTUATORS

Double acting cylinders built in compliance with ISO 6020-2 and DIN 24554.

On board are installed the solenoid valves for emergency actions and proportional valves for control mode, the inductive limit switches (n° 1 open posit. + n° 1 close posit. - SPDT contacts) and position transducer (4 ÷ 20 mA)

ON-OFF HYDRAULIC ACTUATORS

Double acting cylinders built in compliance with ISO 6020-2 and DIN 24554.

On board are installed the solenoid valves and the inductive limit switches (n° 1 open posit. + n° 1 close posit. - SPDT contacts)

Options:

- DPDT contacts (limit switches)
- n° 4 limit switches (n°2 open posit. + n° 2 close posit.)
- spring for failure position

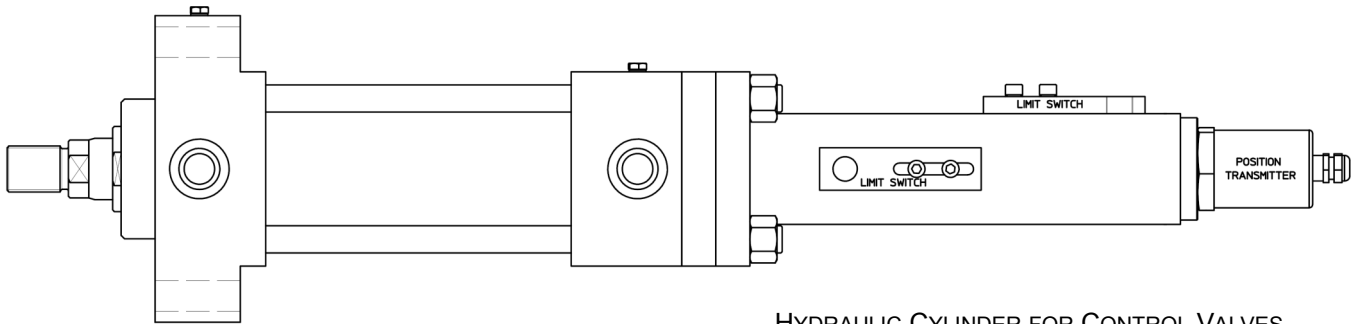

HYDRAULIC CYLINDER FOR CONTROL VALVES

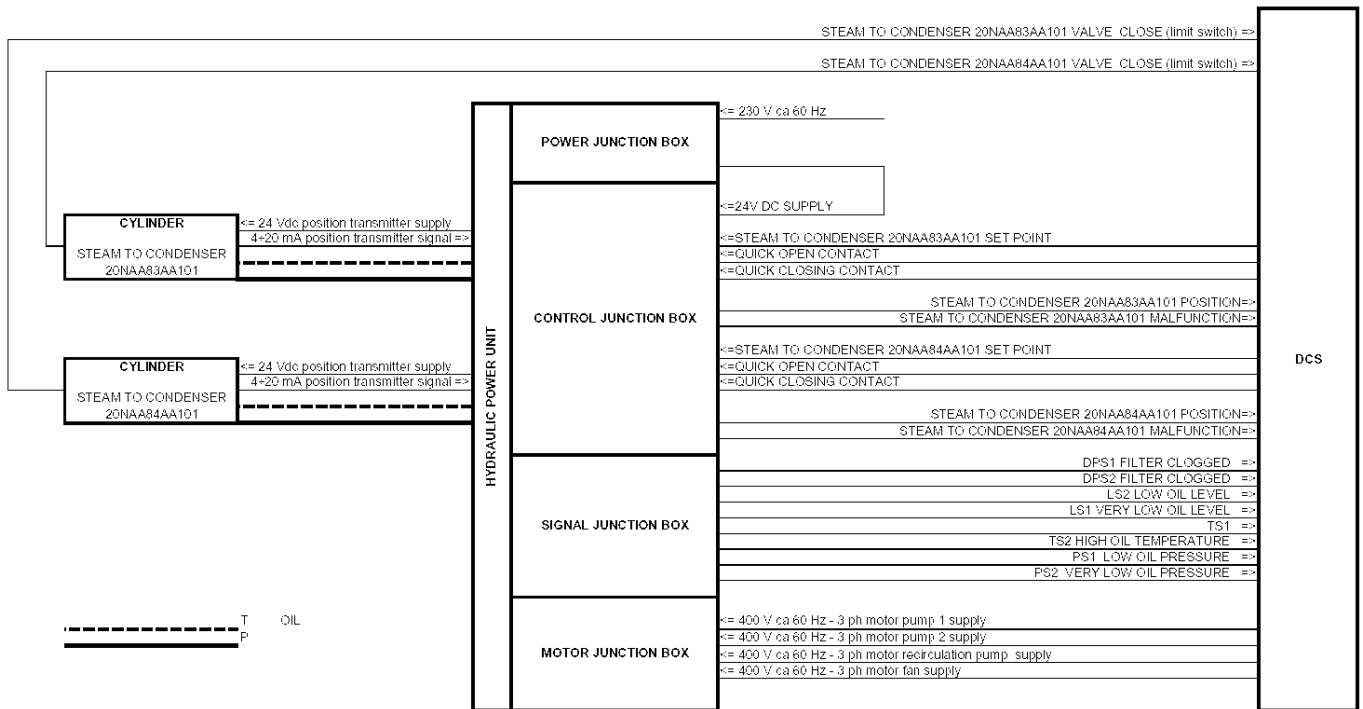

HYDRAULIC CONTROL SYSTEM INTERCONNECTIONS DIAGRAM



PARCOL S.p.A. Via Isonzo, 2 - 20010 CANEGRATE (MI) - ITALY
 Telephone: +39 0331 413.111 - Fax: +39 0331 404.215
 E-mail: sales@parcol.com - <http://www.parcol.com>