

KOSO **PARCOL**

**REDUCING AND
DESUPERHEATING
LIMIPHON CONTROL VALVE
1-9000 SERIES**

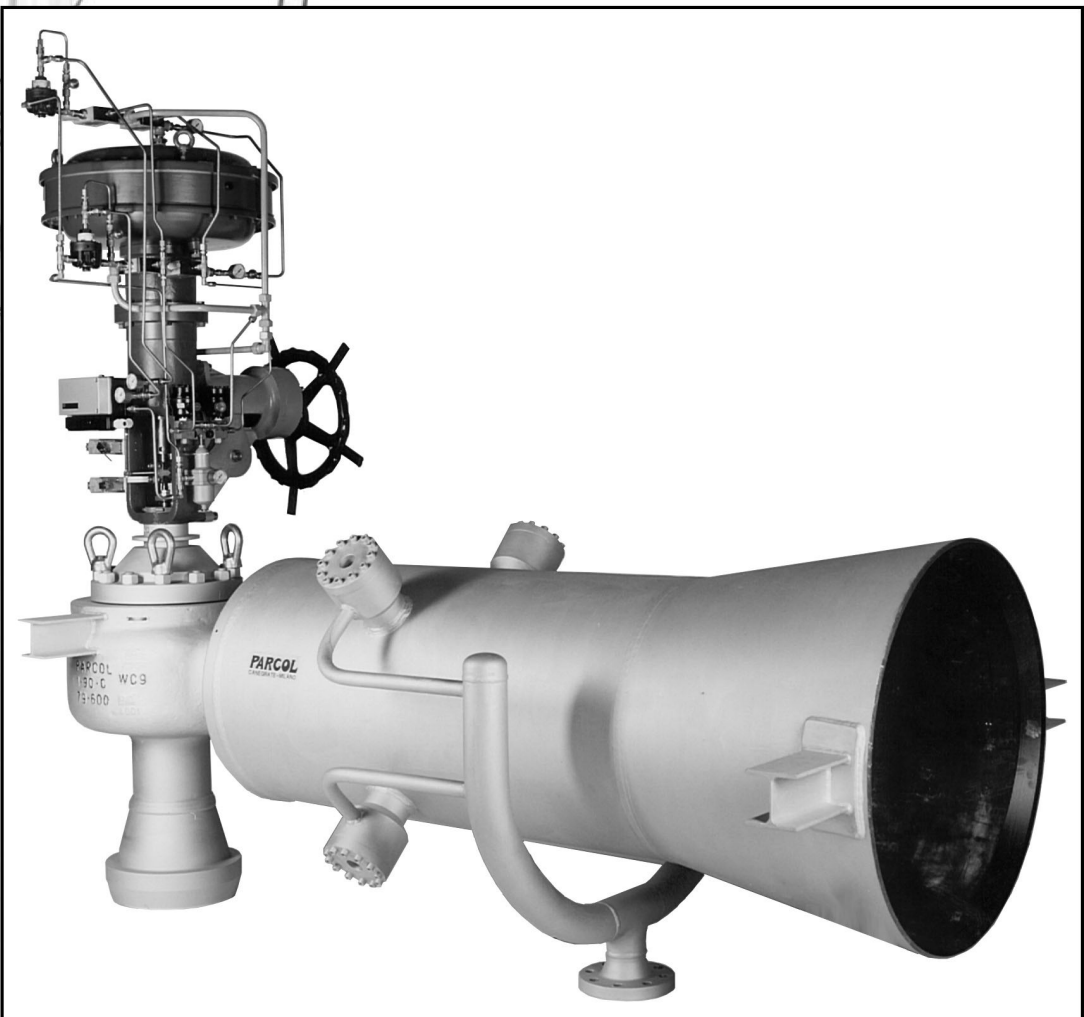

REDUCING AND DESUPERHEATING LIMIPHON CONTROL VALVE - 1-9000 SERIES

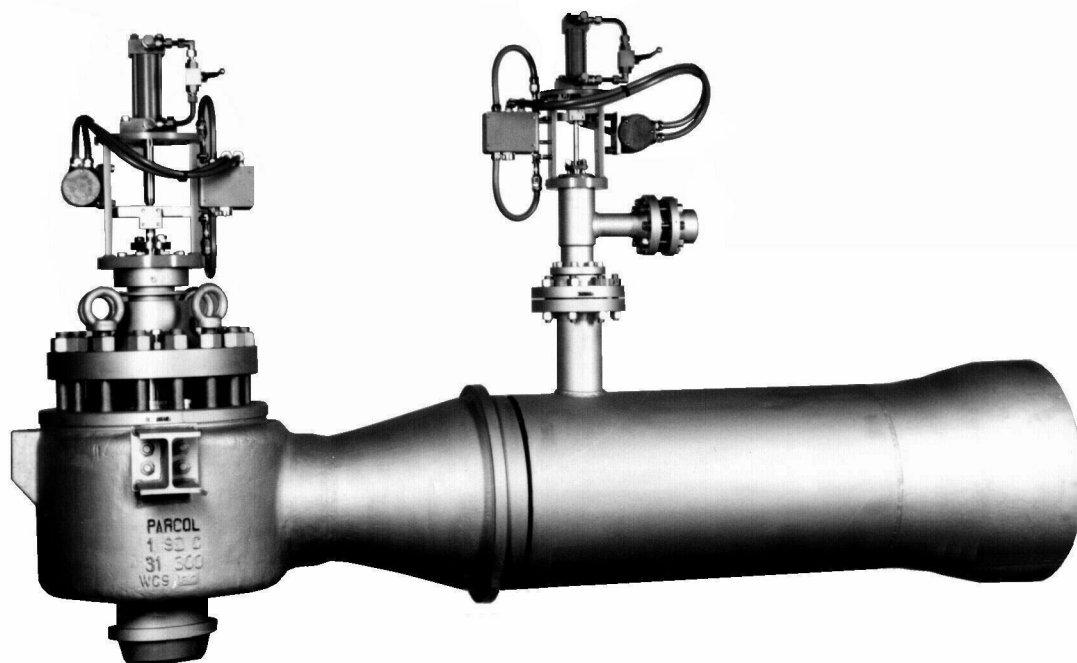

Description

1-9000 series Limiphon valves are widely used in steam pressure reduction and desuperheating stations, quite frequent in turbine by-pass lines.

Limiphon valves are the technically ideal solution for the above process, as well as for all applications where a strong pressure reduction takes place and regular vibration-free operation, maximum noise reduction under significant load changes are required.

As a matter of fact:

1. The pressure reduction takes place through paths whose section changes with the flow rate, thus granting the fluid velocity control in any operation condition
2. The fluid velocity control allows to limit the noise generated by the valve and grants the absence of vibrations and trim wear
3. The Limiphon trim has no construction limits as far as number of stages (so called "lunettes", due to their particular shape) and expansion of flow paths section are concerned. Therefore there are no practical limits for Δp and p_1/p_2 ratio as required by the process.
4. Limiphon valves may be sized in order to generate noise pressure levels comparable to the ones caused by the fluid flowing inside the piping.
In this case they could not be essential for predicting the noise level produced by the whole line.
5. Unlike the valves provided with fixed section silencer installed downstream, Limiphon valves keep their acoustic benefit practically unchanged under different flow rates

Applications

- Universally applicable in all pressure reduction/desuperheating processes where a severe noise pressure level control is required. Noise pressure levels **lower than 90 dB(A) with bare pipe** can be obtained in most severe processes (e.g. UP boilers up to 320 MW).
- Typical and widespread diffused applications in any turbine H.P. and high power L.P. by-pass.
- High turndown with regard to control, noise and regular operation. Such a characteristic is utmost important for starting-up of supercritical units.
- One only limitation: using Limiphon valves on turbine by-pass for high-powered processes (320 MW and over) may involve too high investment costs where severe noise reduction is required. In such cases corrective solutions should be looked for to support the Limiphon performances, such as creating a suitable downstream back pressure or a more suitable piping design (configuration, insulation, thickness, etc.).

Codification

1	-	9	X	X	X
Desuperheater type					
0	undefined				
1	No built-in desuperheater				
4	LVL, LVP or LVC spring type nozzle				
5	injection chamber with LVM multiple spring - nozzles type				
6	servo operated Spraysat				
7	steam-assisted fixed nozzle				
Downstream silencer type					
0	undefined				
1	no downstream second stage				
4	expansion downstream fitting with drilled disk or basket				
5	HAS reactive silencer				
Body shape					
1	straight-way - flow under the seat				
4	angle - bottom inlet, flow under the seat				
6	angle - side inlet, flow over the seat				
8	off-set - bottom inlet, flow under the seat				

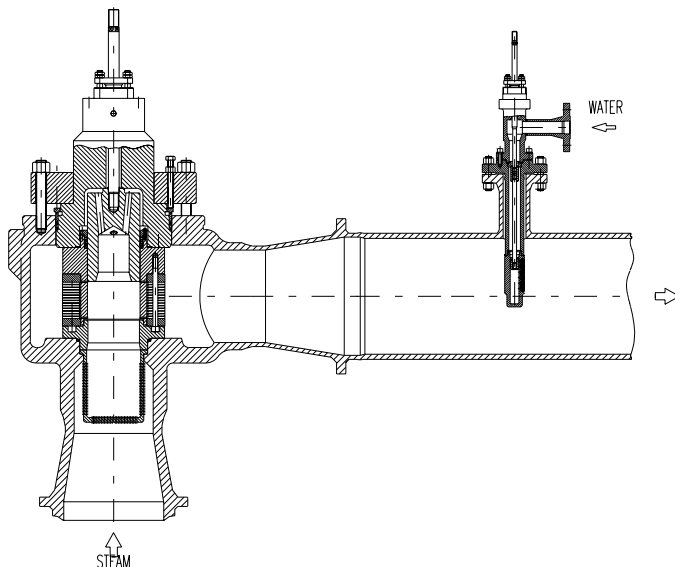

1-9416 Limiphon valve angle body with bottom inlet - sliding and adjustable body/bonnet gasket - balanced plug - filter under seat - V leakage class - downstream chamber with Spraysat desuperheater - Universal solution with no limitation with regard to capacity, turndown, noise control and pressure ratios and differentials

Design features

- body**
- models* – straight-way or off-set - angle body with bottom or side inlet - straight- way and big angle bodies ($DN_2 \geq 16"$) are normally cast; others are built by welding forged or wrought pieces.
 - the desuperheater is mounted in a body extension (injection chamber) welded to body outlet connection
 - for biggest outlet sizes (over 24") the desuperheater may be supplied separately and ready for on-line welding to Limiphon body
 - sizes* – from 6" to 20" for straight-way bodies having equal inlet/outlet DN - angle bodies have different inlet/outlet DN, which are defined according to service conditions and pipe dimensions
 - ratings* straight-way – max ANSI 2500 up to 12" and max ANSI 600 from 14" to 20"
 - angle body – selected according to service conditions and with no practical limitations - different inlet/outlet ratings are normally supplied
- trim**
- all models are quick change type; the Limiphon disk stack can be removed from the top
 - a *basket filter* removable from the top, having filtering capacity suitable to protect the Limiphon trim from solid particles, is normally installed under the seat ring of 1-9100, 1-9400 and 1-9800 flow-to-open models
 - the *plug* may be unbalanced and totally or partially balanced according to selected flow action (to-open or to-close), available actuator type and required leakage class
 - piloted design also available for 1-9600 model with side inlet
 - the Limiphon stack consists of integral disks for 1-9600 series and for other models having small trims (seat dia. ≤ 112 mm) - separated disks in other models. The control characteristic is normally linear or with increasing gain along the travel where it is necessary to correct inconveniences caused by p_2 change versus flow rate (e.g.: discharge to condenser).
- construction materials**
- body and bonnet in carbon steel and CrMo alloy steel according to operating conditions
 - forged bodies are built in A182F91 steel for project temperature over 545°C
 - plugs, cages and seat rings normally made in stellited or nitrided F6NM
 - Limiphon stack is normally made in 1-4913 or CA6NM - AISI 430 steel for temperature under 400°C
 - the external washer spring is built in AISI 422 steel or other equivalent material
- leakage class** (*according to IEC 60534-4*)
- unbalanced and piloted plugs: class V and better
 - plug balanced by graphite inserts: IV S1 for standard model - V class may be obtained where electrical or hydraulic actuators are used; available also for improved stiffness pneumatic actuators

Selection

Since the different models of 1-9000 series Limiphon desuperheating valves may be considered equivalent under the functional view point and mainly the acoustic one, the selection is based on other parameters here listed in importance order:

pipng layout, thermal shocks, leakage in closed position, condensate drainage, fail-safe action of the fluid.

Piping layout

The flow direction in valve body is often imposed by the end user, due to particular piping requirements, design practice, or to meet the path of existing layouts.

1. straight-way installation – 1-9100 series valve must be installed, or alternatively the off-set 1-9800 model, which covers the size limits of straight-way cast body design
2. angle body installation – where vertical position of the actuator and bottom inlet are required the 1-9400 series valve should be selected, while the 1-9600 should be preferred where the bottom outlet is necessary.
 - where the actuator orientation is not a must due to limited needs for its setting-up and maintenance, different solutions may be adopted.

Thermal shocks often occur in 1-9000 series valve operation in turbine by-pass lines, due to their typical emergency function and frequent strokings during start-ups. The Parcol valve design grants, thermal gradients in body walls up to 6 °C/min, with no practical limits to start-ups number. More severe conditions must be carefully evaluated.

1-9000 series valves may be classified as follows in order of decreasing the thermal shock resistance:

- 1-9600 – body and main plug guide are constantly at upstream temperature, both with unbalanced and balanced or piloted plugs - The body design temperature when valve is closed is the saturation one at upstream pressure Applications with very high temperature and relatively low pressure (e.g. some L.P. by-pass types) must therefore carefully evaluated.
- 1-9400 and 1-9800 – only where plug balanced by seal rings is provided the body temperature in closed position is nearly the saturation one at upstream pressure.
- 1-9400 and 1-9800 – provided with unbalanced plugs - In closed position the temperature of body and plug guide is near to the downstream one.
- 1-9100 – the same considerations are valid also for this model - However the body cast design of this straight-way model is less suitable to tolerate significant thermal gradients .

Satisfactory **leakage class** (IVS1) may be obtained with plugs balanced by seal rings both in side inlet 1-9600 series models and in the flow-to-close 1-9100/9800 models. When the piloted plug is available there are no limitations for actuator selection, while stiff actuators (hydraulic, electric) are necessary for plugs balanced by seal rings .

Unbalanced actuators grant the best leakage class, mostly in flow-to-close action models (1-9600), but require high performance actuators, thus excluding the conventional pneumatic ones.

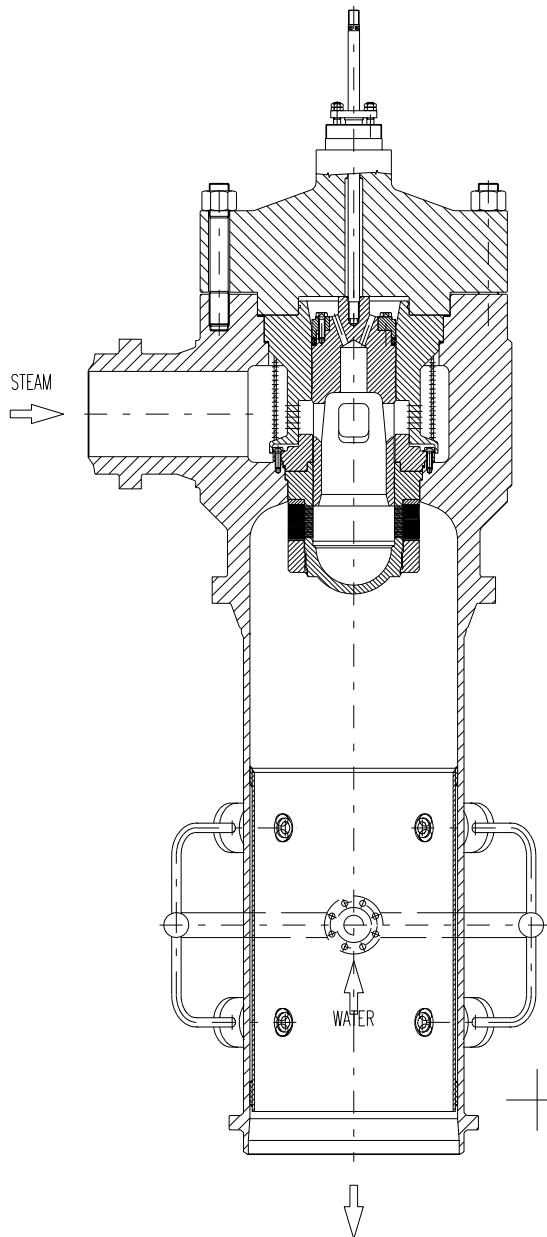

1-9400 / 1-9600 angle valve and 1-9800 off-set valve	
DN x DN	seat Φ
6" x 8"	95/115/127/147
6" x 10"	
6" x 12"	
8" x 10"	127/147/167/185
8" x 12"	
8" x 16"	
10" x 12"	167/185/195/215
10" x 16"	
10" x 20"	
12" x 16"	195/215/246/280
12" x 20"	
12" x 24"	
12" x 28"	195/215/246/280
14" x 18"	
14" x 20"	
14" x 24"	
14" x 28"	215//246/280/307/325
16" x 20"	
16" x 24"	
16" x 28"	
16" x 30"	

1-9615 steam reducing/desuperheating station.
 - H.P. by-pass for high capacity, high turn-down, very high Δp , low noise (<85 dBA) granted at any flow rate, thermal shock proof design suitable for high cold start - ups number.
 The reducing valve is a flow-to-close action Limiphon 1-9612 model
 - balanced plug for V leakage class
 - perfect tight shut-off possible with unbalanced or piloted plugs
 - inlet protecting cage filter
 - baricentric distribution LVM desuperheater

1-9100 series straight-way valve						
DN	6"	8"	10"	12"	16"	20"
seat Φ	73	117	147	185	215	280
	95	127	167	195	246	307
	117	147	185	215	280	325

Condensate draining is greatly necessary in turbine by-pass lines, as they are kept normally closed. When valve opens (very fast in case of load rejection or turbine trip), the condensate accumulated upstream the valve may be carried at high velocity through the valve body and, in addition, flashing may occur. Also condensate can be corrosive due to trace amounts of carbon dioxide introduced to feed water when it is treated. To prevent erosion and corrosion problems, it is mandatory to drain the piping upstream the Limiphon valve both through steam traps and by designing the piping path so to collect the condensate in the direction of the trap. Also the valve body design helps condensate to drain; here it is the models list in order of decreasing efficiency:

- 1-9400 – intrinsically draining - just necessary to avoid siphons in upstream piping
- 1-9800 – necessary just a slope of upstream piping toward traps
- 1-9600 – upstream slope grants the complete self-drainage, except the possible pockets in big bodies
- 1-9100 – straight- way model requires the lower body section to be drained through an appropriate connection

The **fluid action** is normally flow-to-open, since the flow direction is always oriented inward the Limiphon stack - When the fail-safe action is required the fluid action may be replaced by the one of single acting actuators which is provided by accumulators of mechanical energy (springs) or pressure energy (air or oil).

Anyway the fluid action may be obtained by partial plug balancing (about 80%). When such action tends to close the valve, actuators (and mainly their stiffness) must be selected by taking into account the forces to be faced near to the closed position.

Sizing

Limiphon valves are sized according to Parcol proprietary method, which includes the noise prediction according to IEC 60534-8-3.

The trim is designed for specific operation conditions on the basis of the standard port list here below included. Limiphon stacks may be very quickly machined by using CAD/CAE/CAM advanced technologies; by this way it is useless to standardize them and to keep stores.

When the desuperheater is supplied together with the pressure reducing valve the acoustic sizing takes into account the particular configuration of valve+desuperheater assembly by attributing to the water injection an acoustic benefit, which is a function, besides the injector type, also of the ratio w between water and steam flow rate. The best acoustic benefit is obtained by using LVM type multiple spring-nozzles; it may be calculated by the equation: $\Delta L_w = 38 \cdot w^{1.5}$.

Limiphon applications on by-pass to condenser require careful analysis and accurate data concerning the pressure downstream the pressure reducing/desuperheating unit, especially when pressure drop is generated by the fixed area dumper usually installed on valve discharge. Inaccuracies in p_2 evaluation may significantly affect the line noise, due to the possible change of Limiphon noise level as shown here below in the diagram. The similar effect of p_2 reduction due to flow rate change is taken instead into account in Limiphon sizing.

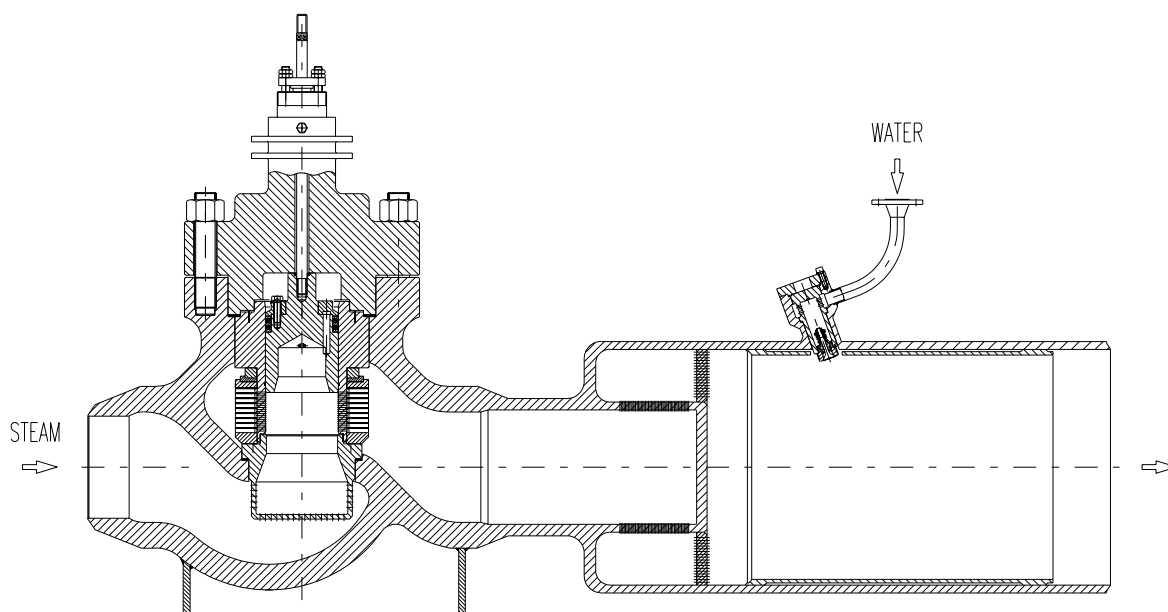
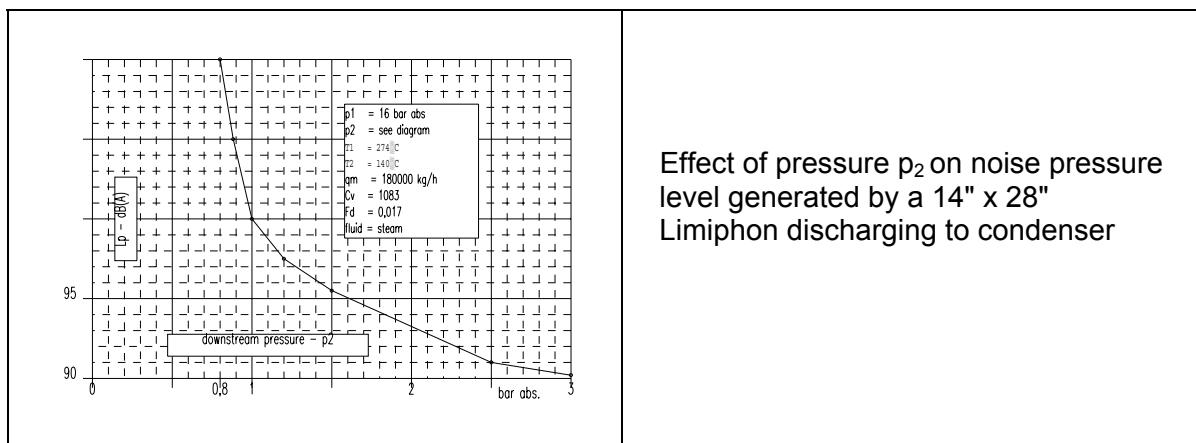

*1-9154 - Limiphon reducing/desuperheating valve
 straight-way cast body - bottom inlet- filtering basket under the seat - balanced plug with inserts - V leakage class - HAS silencer on the outlet downstream chamber with spring-nozzle LVL single type - Suitable for moderate flow rates , turn-down and p_1/p_2 ratios - high pressure differentials - very low noise level*

KOSO PARCOL S.r.l. a socio unico
 Sede legale: Via Isonzo, 2, 20010 Canegrate (Milano) ITALY
 Partita IVA e Codice Fiscale 09684900963
 Cap. Soc. €110.000,00 | R.E.A. MI – 2106767
 Phone: +39 0331 413111 | Fax: +39 0331 404 215

