

**3-4000 SERIES  
DESUPERHEATERS**





## 3-4000 SERIES DESUPERHEATERS

PARCOL 3-4000 series desuperheaters are used to reduce the steam temperature by directly water injection inside the superheated steam flow.

The above series includes 3-4100 variable area and 3-4500 fixed area models.

LV variable area series, including LVP and LVM models, allows solving the most common desuperheating problems without practical limitations in flow rate and operating conditions.

Fixed area LF nozzles, on the contrary, are designed for limited power processes with limited load changes.

## 3-4100 VARIABLE AREA MODELS

### Classification

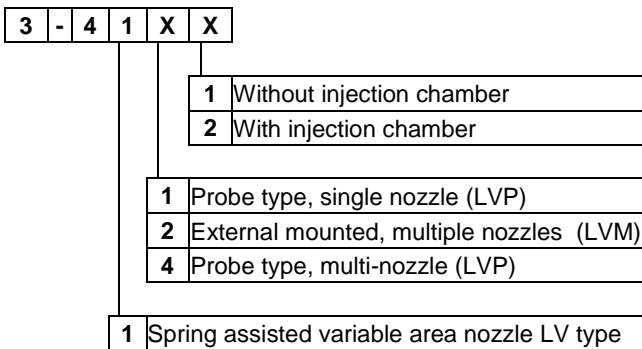

All the models are provided with the basic variable area spring-loaded LV nozzle.

## LV - VARIABLE AREA NOZZLE

### Description and operation

The LV nozzle is the basic component of all 3-4100 desuperheaters; it is threaded and locked by a special tab washer (5).

Main components of the nozzle are (see fig. 1):

- plug (1)
- nozzle body (2)
- spring (3)

The spring, compressed by the ring nut (4), keeps the plug pressed against the nozzle seat until the  $\Delta p$  between water and steam exceeds its preload. When the plug opens the water circulates through nozzle openings, which, due to their multi-helical design, make the flow to whirl before it gets in contact with the inside plug cone.

Due to such a special path, the water coming out of the 85° conical blade shaped nozzle is perfectly atomized.

While in a traditional type fixed area nozzle, decreasing the water flow rate the sprinkling velocity also decreases being the outlet section constant, with a LV nozzle type the plug (1) sets automatically reducing the meatus with the nozzle body (2), reducing the differential pressure up to balancing the spring load (3). Thanks to spring preload, water velocity in the meatus is kept satisfactorily high also for low water flow rates.

Therefore, Parcol variable area spring-loaded LV nozzles executions guarantee steady sprinkling efficiency independently of water flow rate.

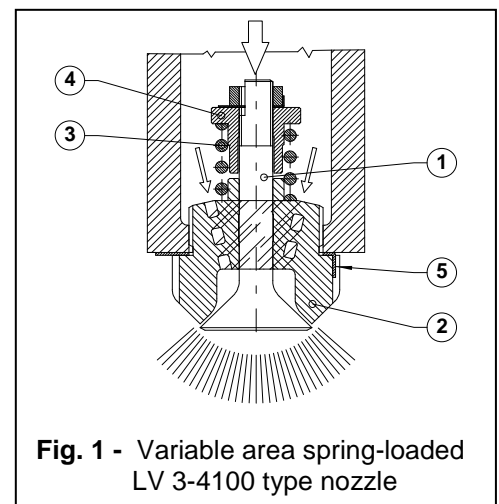

**Fig. 1 - Variable area spring-loaded LV 3-4100 type nozzle**

Such a capability is correctly called *sprayability* (instead of the more known *rangeability*) to better identify the intrinsic atomization capability versus flow rate change taking into account also water  $\Delta p$  changes across the nozzle.

### Characteristic data

- size** : LV1, LV3, LV5, LV7 and LV8
- flow rates** : see data of desuperheaters provided with LV nozzles.
- characteristic curve** :  $C_v$ /travel and travel/ $\Delta p$  characteristic curves are summarized in the diagram of Fig. 2, which plots  $C_v$  as a function of  $\Delta p$ , for various values of set pressure.
- settings** : standard setting = 3 bar  
 Different settings (from 1 to 5 bar) may be used for special requirements.  
 The 3 bar value is a compromise between the necessity to keep a certain back pressure on the control valve and a minimum seating force on the plug and also to increase the control range of the desuperheater.
- sprayability** :  $C_{v_{max}} / C_{v_{min}} \cdot \sqrt{\Delta p_{max} / \Delta p_{min}}$  where  $\Delta p_{min}$  is approximately 3 bar.

The ratio  $C_{v_{max}}/C_{v_{min}}$  can be determined accordingly to the minimum acceptable spray quality at minimum steam flow taking into account of nozzle size and superheated steam process conditions.

$C_{v_{min}}$  and  $\Delta p_{min}$  values can be drawn out by the Fig. 2 as a function of setting pressure  $p_t$ .

Ex: nozzle LV1,  $p_t = 3$  bar,  $\Delta p_{max} = 30$  bar,  $\Delta p_{min} = 3.5$  bar,  $C_{v_{max}}/C_{v_{min}} = 11.4$  (from figure 2).

$$Sy = 11.4 \cdot \sqrt{30/3.5} = 33.4$$

- materials** : plug : 17-4-PH
- nozzle body : 1-4913
- spring : Inconel X-750
- tab washer : AISI 304

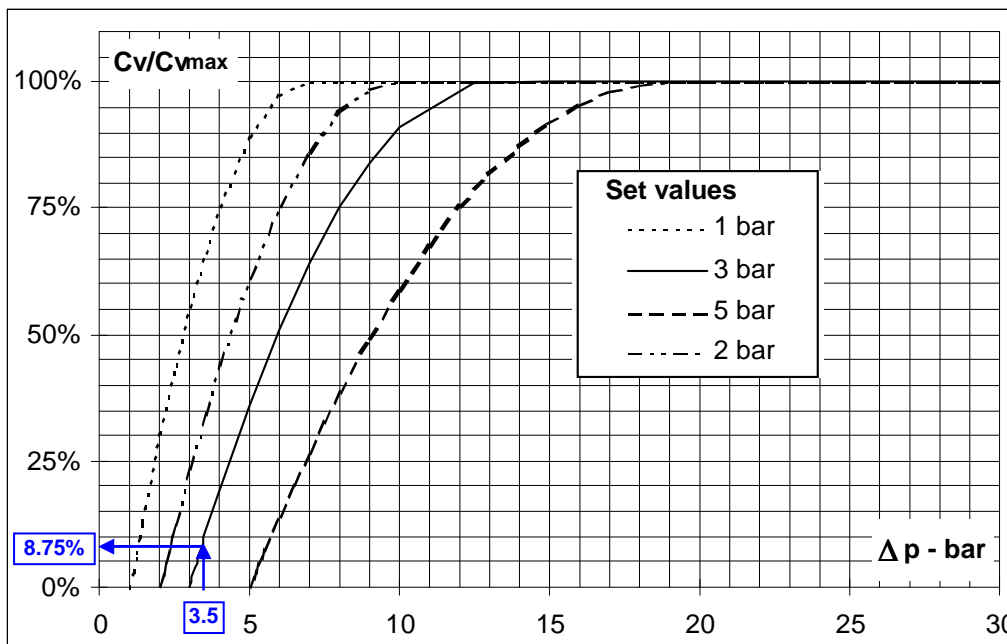

**Fig.2**  
 $C_v$  versus  $\Delta p$ .  
 The maximum plug travel occurs with different  $\Delta p$  values depending on the value of nozzle set pressure.

## LVP - PROBE TYPE DESUPERHEATER

It consists of a tubular flanged element where one or more downstream oriented LV nozzles are mounted.

The desuperheater is fastened on a pipe nosepiece, the length of which is adjusted, according to the pipe diameter, to keep the center of the spraying area close to the pipe axis.

Two versions are available: injection chamber to be welded to the pipe (3-4112 series), or flanged (3-4111 series) for connection through a pipe nosepiece having the dimension listed apart.

The injection chamber of 3-4112 model may be provided with inside protection liner, should it be required by the operating temperature.

One LV nozzle only is provided for in the standard design, two nozzles can be mounted on the same probe for special applications.

The nozzle orientation, with regard to flow direction, is granted by a gauge pin, whose seat must be drilled on site on the nosepiece flange, should the desuperheater be supplied disassembled (3-4111 series).



### Characteristic data

<b>size</b>	: water side: from ½" to 2" steam side: from 2" to 6"
<b>connections</b>	: 3-4111 model – ANSI, UNI, DIN flanges – BW connection on request 3-4112 model – BW connection according to pipe size
<b>ratings</b>	: water side: ANSI 150 ÷ 1500 (PN 16÷250) steam side: ANSI 150 ÷ 1500 ( PN16÷ 250) higher ratings on request
<b>flow rates</b>	: may be calculated by common equations (see 1-I bulletin) using the Cv's listed in the table. The water mass flow rate can not exceed in any case 25%÷26% of the steam one
<b>sprayability</b>	: for single nozzle desuperheaters see LV nozzle basic values. for multiple nozzles having different sizes and/or settings general turndown improvements are possible.
<b>design</b>	: for water inlet perpendicular to the pipe (standard) : integral forged, supplied with welded nosepiece for water inlet parallel to the pipe (on request) : forged or laminated parts welded together
<b>materials</b>	: body : Carbon or Cr-Mo steels according to operating temperatures injection chamber : same material as the pipe

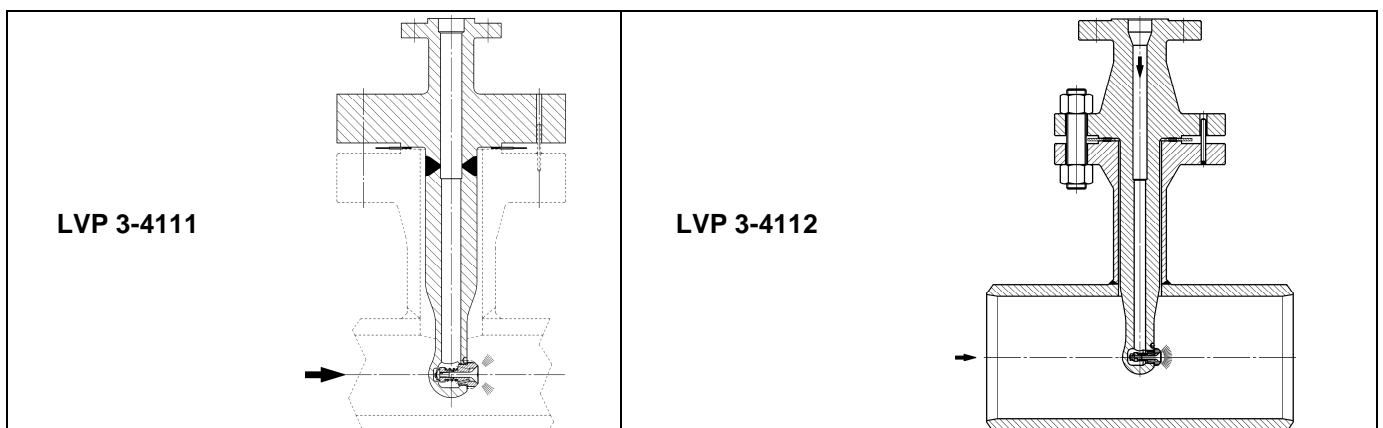

## Flow coefficients LVP models

maximum obtainable Cv <sup>(1)</sup>				Δp min bar	Δp max bar	
nozzle number	1	2 <sup>(4)</sup>	3			
Nozzle type	LV-1	0.8	1.5	2.2	(2)	30
	LV-3	1.6	3	4.4		
	LV-5	3.15	6	9		
	LV-7	6.3	12	18		
	LV-8	9	17	25		
Max injectable water % <sup>(3)</sup>		22%	24%	26%		

(1) - Maximum reachable Cv values at maximum plug opening.

(2) - Value corresponding to spring setting (standard value is 3 bar).

(3) - % value referred to steam flow rate to be desuperheated.

(4) - LVM 3-4122 model to be preferred for equipment provided with two nozzle chamber

Nozzle size	LV-1	LV-3	LV-5	LV-7	LV-8
steam side connection	2"	3"	4"	4"	6"
minimum steam pipe DN (*)	4"	6"	8"	8"	12"
water connection DN	1/2"	1"	1.1/2"	2"	2"

(\*) Model without pipe protecting liner

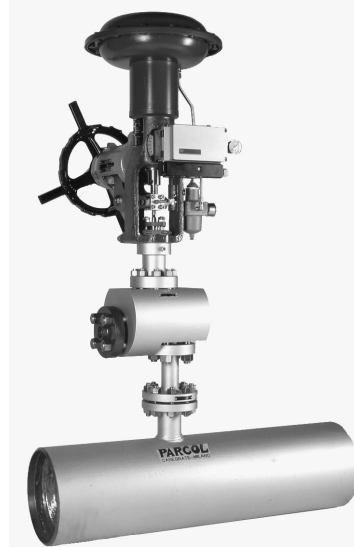

**Limiphon 1-9711 + LVP 3-4111**

Integrated design for desuperheating water reduction and control, suitable for high water-steam differential pressure.

## Overall dimensions LVP models

TIPO UGELLO Nozzle type	B	C	D	E	H
LV-1	140	1/2"	2"	49	270
		3/4"			
	170	1"	2" ≤ ANSI 600 2" ≤ PN 64 2" ≥ ANSI 900 2" ≥ PN 160		
LV-3	180	1"	3"	73.5	329
LV-5	200	1.1/2"	4"	97	385
LV-7	200	1.1/2"	4"	102	393.5
		2"			
LV-8	230	2"	6"	140	510

DN	A					F	G
	LV-1	LV-3	LV-5	LV-7	LV-8		
4"	250	300	350	350	450	150	530
6"						200	600
8"						200	630
10"						200	650
12"						200	680
14"	275	350	350	450	200	700	
16"	300				200	720	
18"	325	325	375	375	450	200	750
20"	350	350				250	820
22"	375	375	400	400	450	250	850
24"	400	400	425	425	450	250	870
26"	425	425	450	450	475	250	890
28"	450	450	475	475	500	250	920

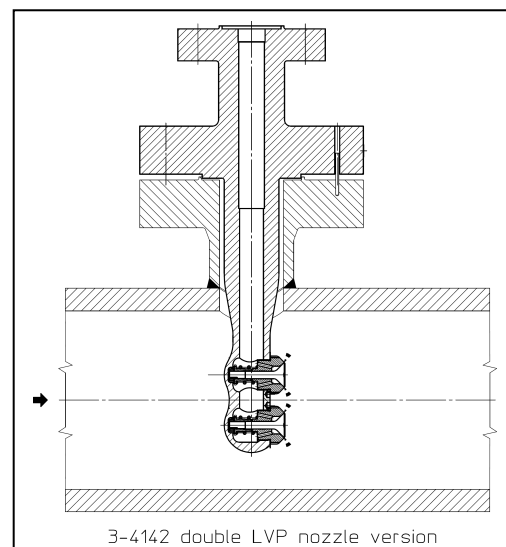
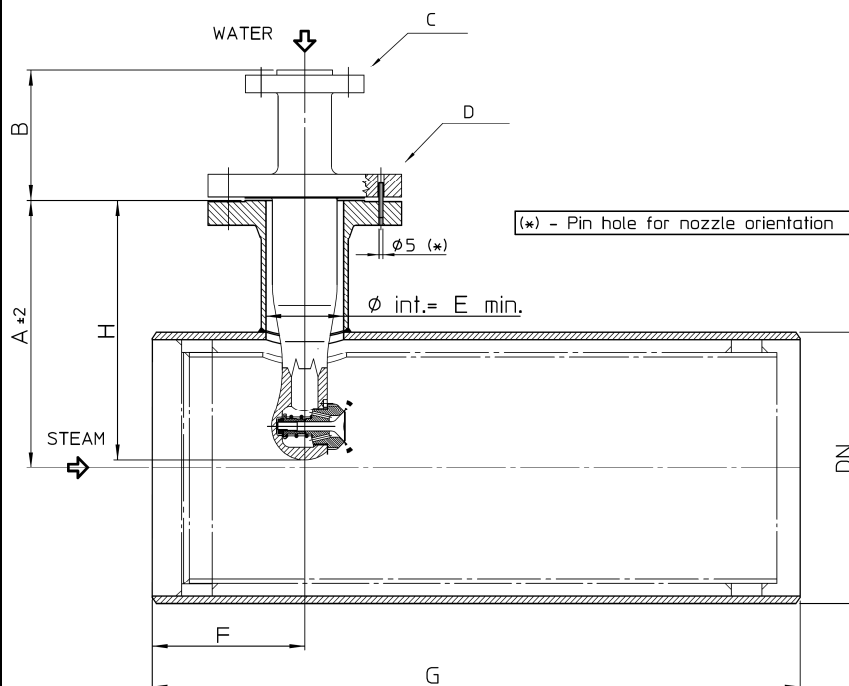

Above dimensions may change according to operating conditions and must be confirmed in the order

## LVM – EXTERNAL MOUNTED, MULTIPLE NOZZLES DESUPERHEATER

The LVM 3-4122 model desuperheater is composed by more elements (or injectors) connected to one another and welded to an injection chamber that shall be installed on the piping by a BW welding.

Each injector is composed by a LV nozzle threaded inside a drilled cage inserted in a stub pipe welded on the injection chamber and closed by a flanged bottom.

The injectors are uniformly distributed on chamber and are oriented perpendicularly to the pipe axis. A piping leading to a single inlet makes up the connection among the various injectors.

Water distribution piping system is purposely designed to avoid dangerous stresses generated by different water and steam temperatures.

According to the operating conditions specified apart, the injection chamber may be provided with an inside protection liner (see Parcol Bulletin 1-XI – Steam Conditioning Manual for further details).

The LVM design may be provided with nozzles having different size and settings, for good performance at various regimes, and mainly to improve sprayability.

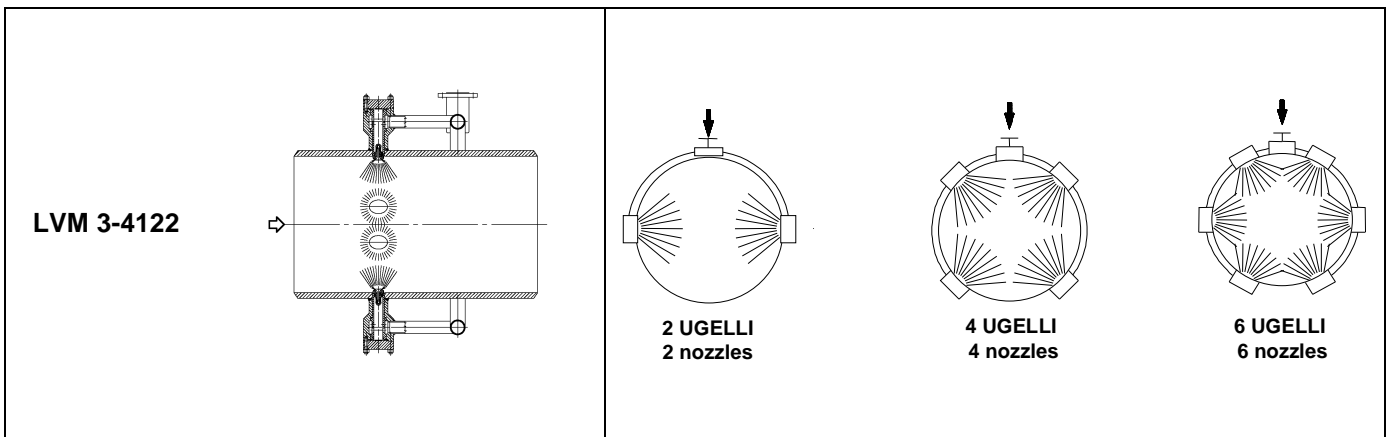

ref.	Description	Material
72	NUT	ASTM 194-4
73	STUD	ASTM 193 B7
75	GASKET	AISI 321 + GRAPHITE
78	NOZZLE HOLDER	ASTM A 182 F6NM
81	COVER	ASTM A105
82	GASKET	AISI 321 + GRAPHITE
86	TAB WASHER	AISI 304
88	NOZZLE ASSEMBLY	VARIOUS

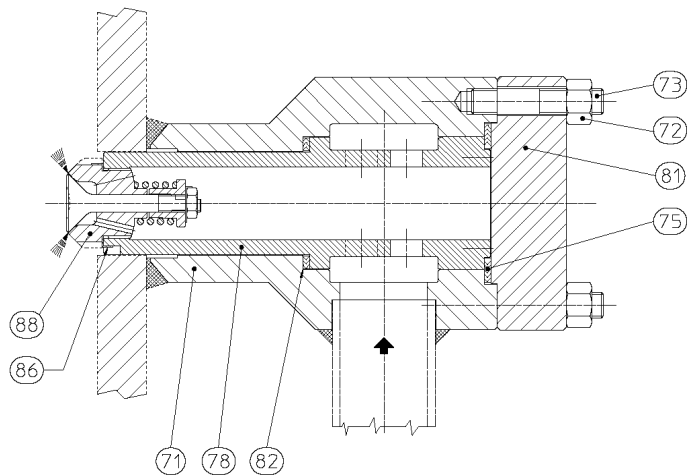



## Characteristic data

<b>size</b>	: 1" to 4" for water connection; 4" to 40" for the injection chamber
<b>connection</b>	: ANSI, UNI, DIN flanges for water connection BW for the injection chamber according to pipe size
<b>rating</b>	: water side : ANSI 150÷1500 (PN16÷250) steam side : ANSI 150÷1500 (PN16÷250)
<b>flow rate</b>	: may be calculated by using the Cv listed apart as a function of nozzle number the max water versus steam flow rate can not exceed the value shown in Cv table
<b>sprayability</b>	: see values of basic LV nozzle. Turndown improvement is possible through a combination of different nozzle sizes and settings
<b>design</b>	: fabricated by welding together forged or laminated parts
<b>material</b>	: desuperheaters: Carbon or Cr-Mo steels according to operating temperature injection chamber: same material as the pipe internal liner: Cr-Mo steel



PRDS 1-5945 : 1-6948 DN 20" ANSI 600 with LVM 3-4122 desuperheater installed downstream.



## Flow coefficients LVM models

max obtainable Cv (1)						$\Delta p$ min bar	$\Delta p$ max bar	
Number of nozzles	1	2	4	6	8			
Nozzle type	LV-1	0.8	1.5			(2)	30	
	LV-3	1.6	3	6				
	LV-5	3.15	6	12	18			24
	LV-7	6.3	12	24	36			47
	LV-8	9	17	33	50			67

### Maximum injectable water quantity

(% value referred to steam flow rate to be desuperheated)

Number of nozzles	1	2	4	6	8
one section	20%	22%	25%	28%	
two sections			30%		33%

(1) - Maximum values reachable at maximum plug opening

(2) - Value corresponding to the spring setting (the standard value is 3 bar).

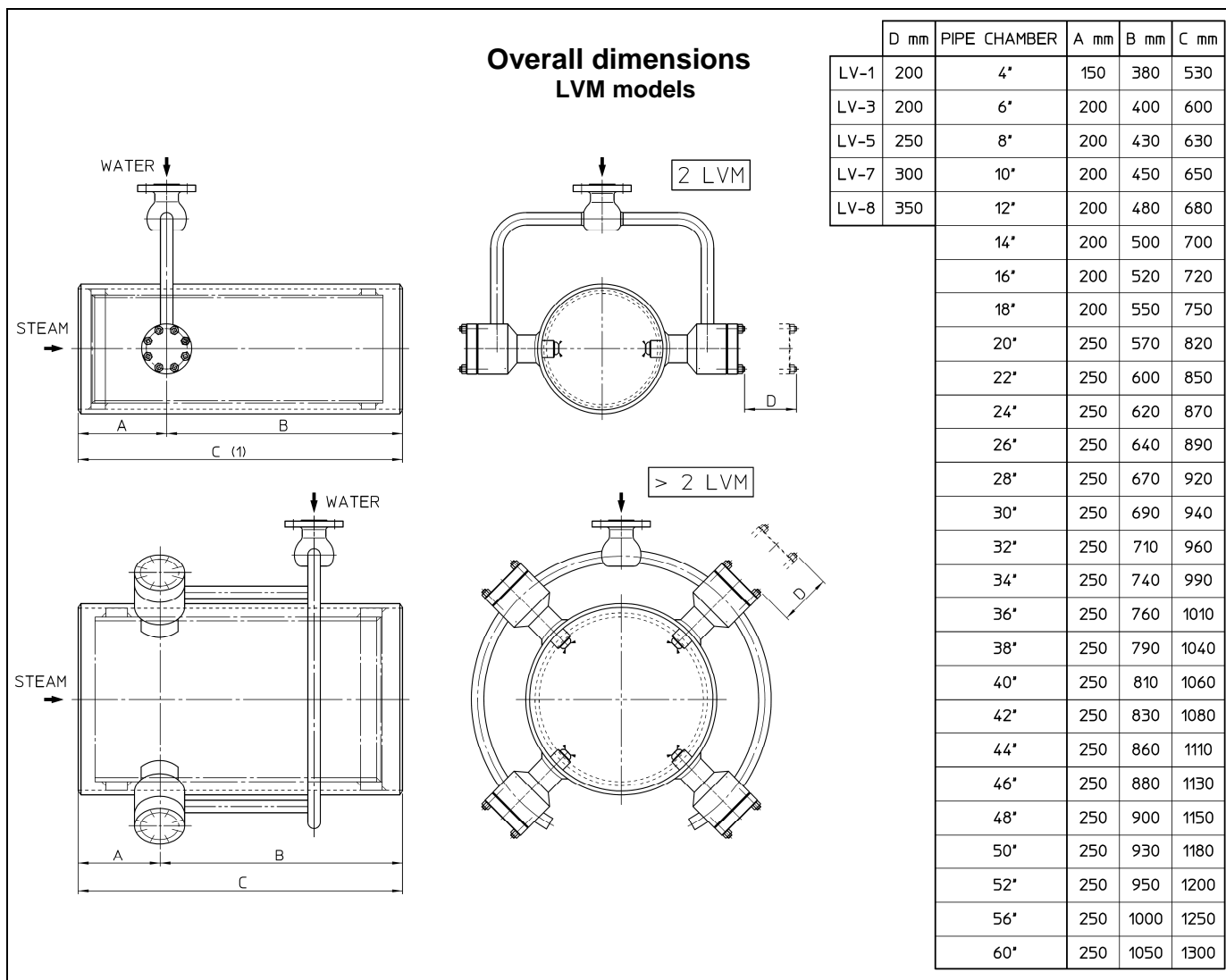

Above dimension may change according to operation condition and must be confirmed in the order



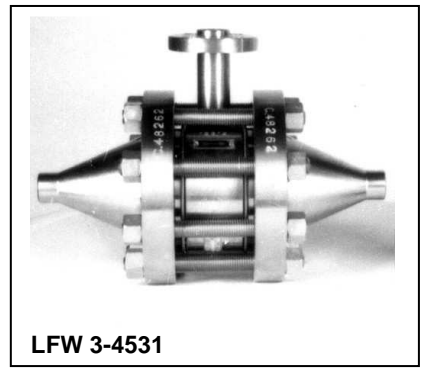
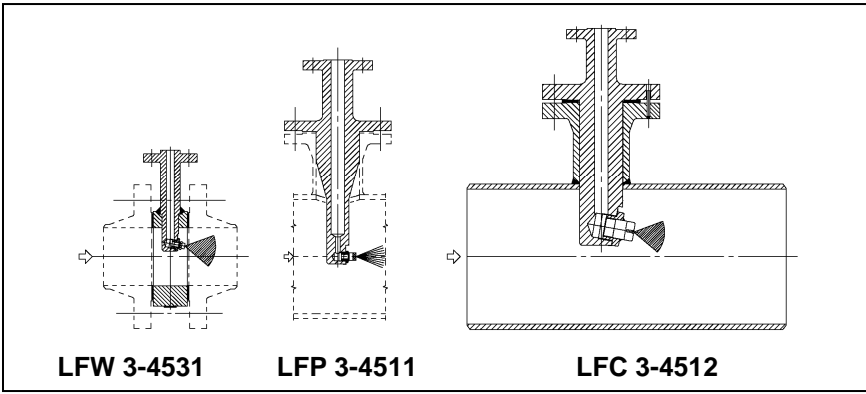

**Flow coefficients  
LF models**

DNw	1/2"								3/4"			1"				
Cv - gpm	0.03	0.04	0.06	0.085	0.11	0.14	0.18	0.3	0.36	0.43	0.6	0.7	0.83	1.1	1.4	2.7

**Overall dimensions  
LF models**

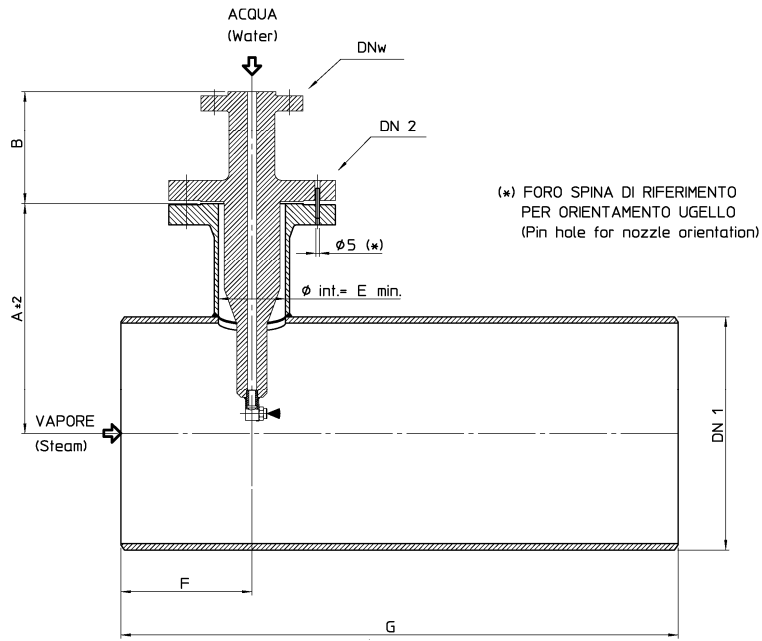

DN 1	A			F	G
	DNw 1/2"	DNw 3/4"	DNw 1"		
3"				150	500
4"				150	550
6"				200	650
8"	250			200	700
10"		300	300	200	750
12"				200	800
14"	275			200	850
16"	300			200	900
18"	325	325	325	200	950

DNw	B	DN 2	E
1/2"	140	2"	49
3/4"	180	3"	73.5
1"	180	3"	73.5

**LFW models**

DN 1 1/2 - 2" - 2 1/2"

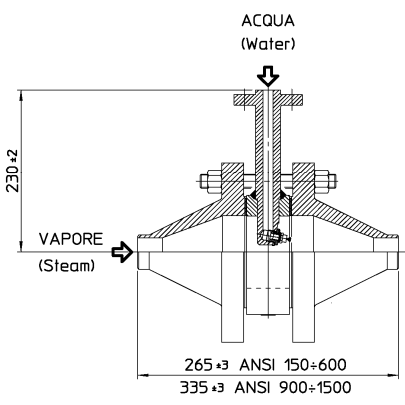

DN 3" - 4"

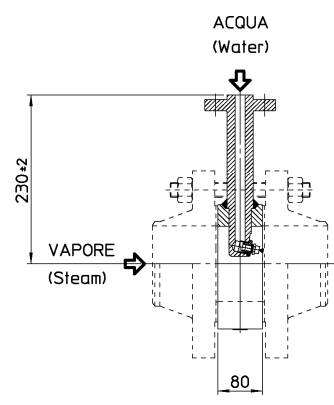

Above dimension may change according to operation condition and must be confirmed in the order

---

**KOSO PARCOL S.r.l. a socio unico**

Sede legale: Via Isonzo, 2, 20010 Canegrate (Milano) ITALY

Partita IVA e Codice Fiscale 09684900963

Cap. Soc. €110.000,00 | R.E.A. MI – 2106767

Phone: +39 0331 413111 | Fax: +39 0331 404 215

**VECTOR**

**kentintrol™**

**ASA**

**KOSO  
HAMMEL DAHL**