

**PRESSURE REDUCING
AND
DESUPERHEATING
STATIONS
1-5700 SERIES**

KOSO PARCOL S.r.l. a socio unico
Sede legale: Via Isonzo, 2, 20010 Canegrate (Milano) ITALY
Partita IVA e Codice Fiscale 09684900963
Cap. Soc. €110.000,00 | R.E.A. MI - 2106767
Phone: +39 0331 413111 | Fax: +39 0331 404 215



I.P. to condenser bypass valve 1-5765

- Inlet: DN 30" ANSI 900 BW
- Outlet: DN 60" ANSI 300 BW
- Port : 443 mm

Body material: SA182 F91 / SA182 F22

Desuperheater: Parcol LVM 3-4122

PRESSURE REDUCING AND DESUPERHEATING STATIONS 1-5700 SERIES

DESCRIPTION

Parcol 1-5700 Pressure Reducing and Desuperheating stations (PRDS) represent the most universal and compact solution for pressure reduction and desuperheating of turbine by-pass lines, discharging both to intermediate or low pressure sections of power stations.

The spherical body shape design, together with the high quality of construction materials, allow a more uniform wall thickness than the conventional ones, fabricated by welding bodies, reducing P/T fatigue effects and improving welded joints quality.

All Parcol desuperheating stations are checked according to TRD 301 methodology and are suitable for not less than 2000 cold startup and 10000 hot startup cycles.

The pressure reduction is mainly achieved through two stages: the first stage has the function to adjust the flow rate by means of a drilled cage trim, the second stage, designed with fixed throttling section, has the double function to generate a backpressure on the first stage by reducing fluid velocity and generated sound pressure level, and to convey the steam towards the injection chamber, at speed and distribution suitable to optimize the desuperheating process.

The second stage has also an absorbing function, acting as silencer towards the noise generated by the first stage. Such a function is remarkable in multi-cage figures, where the clearance between silencers is optimized to reduce noise frequencies between 1kHz to 4kHz, or when a Limiphon disk stack is installed as a silencer.

The desuperheating section, put immediately downstream the second stage, consists of the injection chamber complete with injection nozzles or a different Parcol desuperheater, to be selected according to operation conditions, plant lay-out and required process turn-down.

The downstream water injection allows to preserve valve trim and main body from thermal shock phenomena, while the desuperheating efficiency is warranted by the downstream steam velocity profile produced by the silencer design.

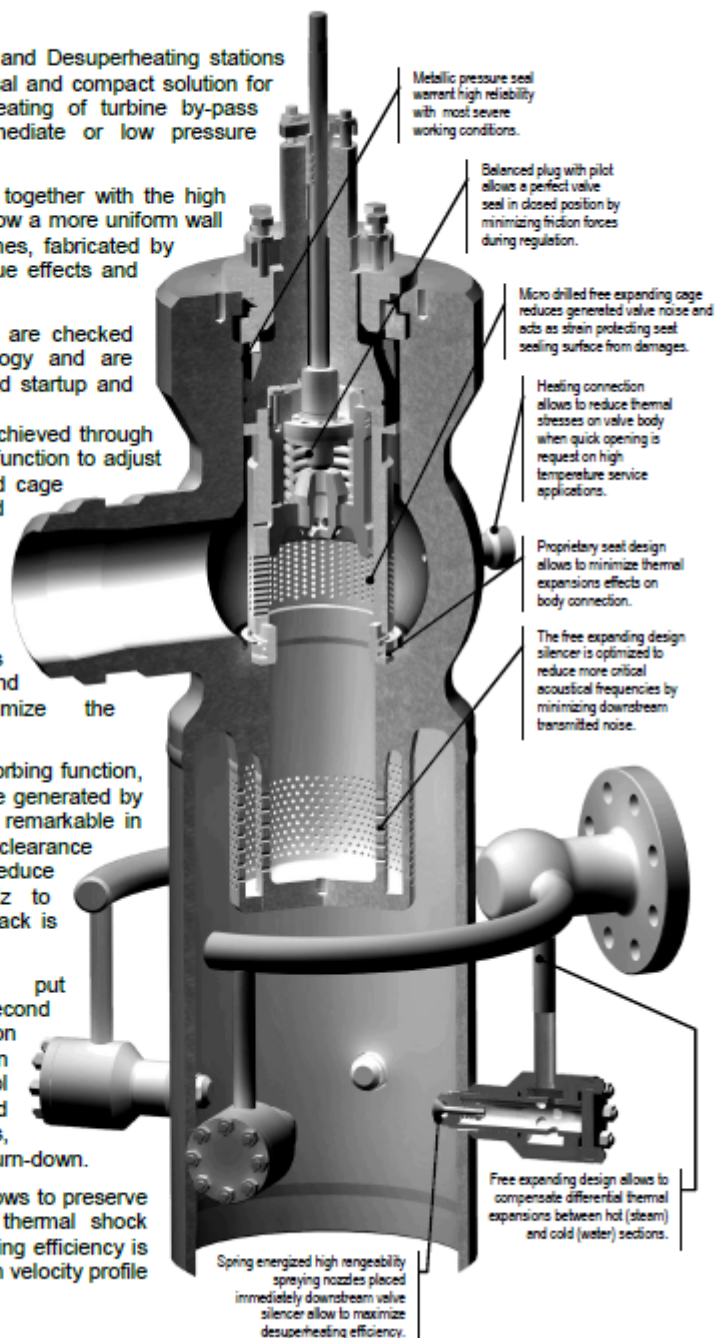

APPLICATIONS

Parcol 1-5700 are the best solution for steam conditioning, combining high performance flow control with high efficient integrated steam desuperheating.

The most significant applications are turbine by-pass without practical pressure, temperature and flow rate limitations.

The high experienced trim materials allow to minimize wear effects also for continuous services requiring minimum maintenance.

A wide range of Parcol desuperheaters can be installed allowing a proper steam conditioning also with high water to steam flow rates and high turndown ratio.

Thanks to the wide range of silencer solutions (including Limiphon disk stack silencer), any reasonably noise level requirement can be satisfied.

For continuous service with high water to steam temperature differential the injection chamber can be provided with built in protective lining to avoid piping damages. See Parcol Bulletin 1-XI for further details.

Parcol 1-5700 are particularly appreciated when straight line pipe layout is not allowed.

Standard actuator is single effect spring return pneumatic diaphragm type equipped with positioner and other accessories for quick or emergency actuation.

Piston hydraulic or electric actuators can be supplied on request.



H.P. to I.P. bypass valve 1-5745

- Inlet: DN 14" ANSI 2500 BW
- Outlet: DN 18" ANSI 2500 BW
- Port: 7"

Body material: SA182 F91

Desuperheater: Parcol LVM 3-4122

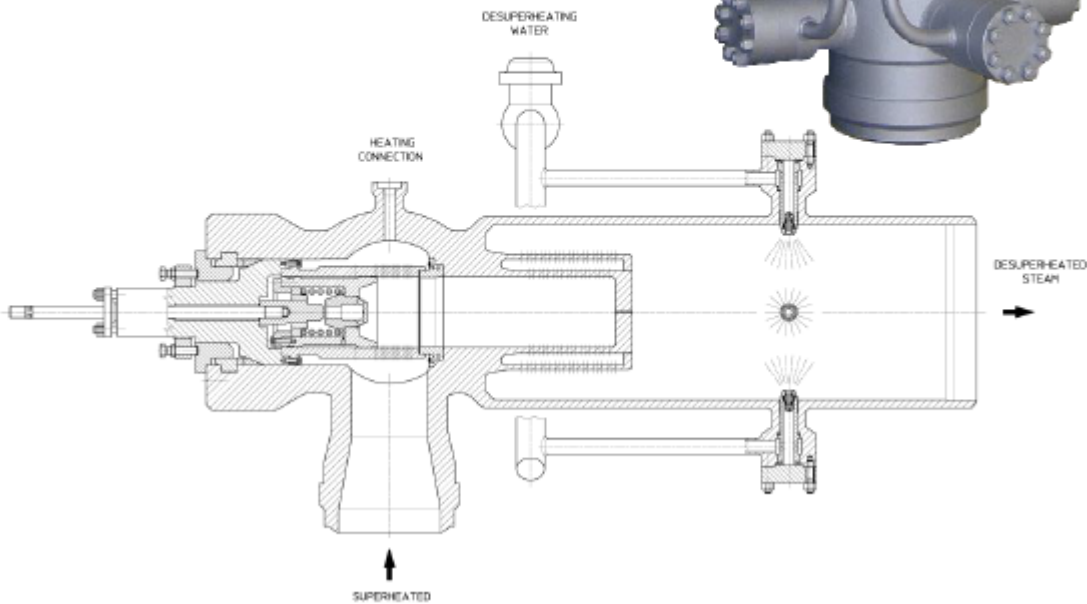

DESIGN FEATURES

Body

- manufactured from fully machined forgings with welded inlet connection and integral downstream injection chamber;
- available: sizes according to service conditions;
- ratings: up to ANSI 2500 (up to ANSI 4500 on request).

Bonnet

- up to ANSI 600: flanged bonnet;
- over ANSI 600: pressure seal.

Trim

- cage-guided balanced plug with pilot;
- first pressure reduction stage is performed by a specially drilled cage;
- seat ring is welded to the body through an easily removable tension free lip-seal;
- quick change seat ring is available on request as special construction.

Silencer

- two different designs are available:
 - 1 to 3 stages diffuser;
 - LIMIPHON silencer.
- the silencer is usually welded to valve body, however, when quick change seat ring is provided, the silencer is clamped between body and seat and can be removed through the bonnet cavity.

Materials of construction

- body and bonnet are usually made of carbon steel and CrMo alloy steels according to line class;
- trim parts are usually made of nitrided or stellite F6NM alloy steel;
- silencer is normally made of CrMo alloy steel, while LIMIPHON stack is normally made of AISI 430 or 12Cr special stainless steel for temperature above 400°C.

Leakage class (according to IEC 60534-4)

- up to class V both for balanced and unbalanced plug.

Packing

- Parcol GRF pure graphite packing specially designed for control application is supplied. Parcol GRF packing provides bi-directional tightness and it is therefore suitable also when vacuum seal is required.



I.P. to condenser bypass valve 1-5745

- Inlet: DN 24" ANSI 600 BW
- Outlet: DN 48" ANSI 300 BW
- Port: 14"

Body material: SA182 F91 / SA182 F22

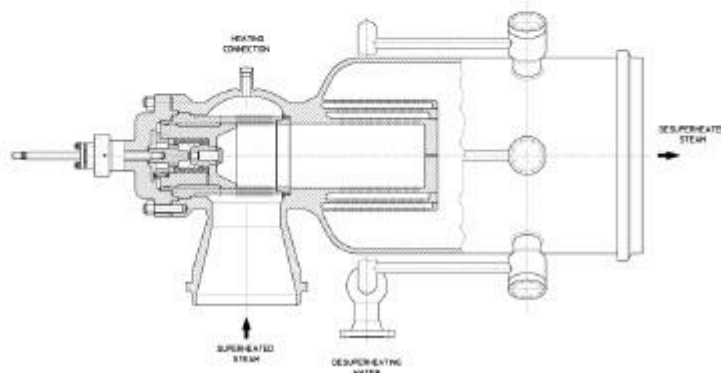
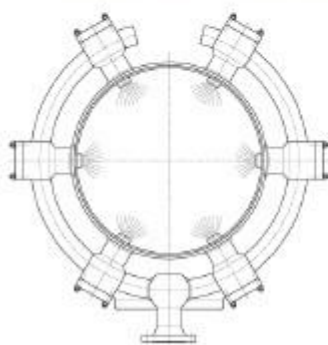

Desuperheater: Parcol LVM 3-4122



NUMBERING SYSTEM

1 - 5 7 X X

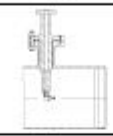
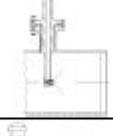
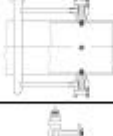
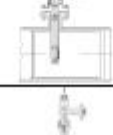
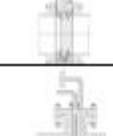
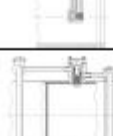
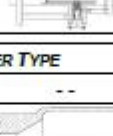
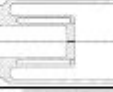
OPTIONS	
QS	Quick change Seat
QL	Quick change Seat and Limiphon silencer (1-5760 only)

DESUPERHEATER TYPE		
0	undefined	--
3	LFP 3-4511 fixed area nozzle	
4	LVP 3-4111 variable area nozzle	
5	LVM 3-4121 multiple nozzle	
6	Spraysat 1-4442 multi nozzles	
7	SprayRing 1-4443 multi nozzles ring	
8	LVPA 3-4111 variable area steam atomized nozzle	
9	LVMA 3-4121 variable area steam atomized multi nozzles	
DOWNSTREAM SILENCER TYPE		
0	undefined	--
1	without silencer	
4	disk or drilled basket type	
6	Limiphon disk stack	

L.P. to Condenser bypass valve 1-5744
 - Inlet: DN 14" ANSI 150 BW
 - Outlet: DN 18" ANSI 150 BW
 - Port: 10"
 Body material: SA105
 Desuperheater: Parcol LVP 3-4112

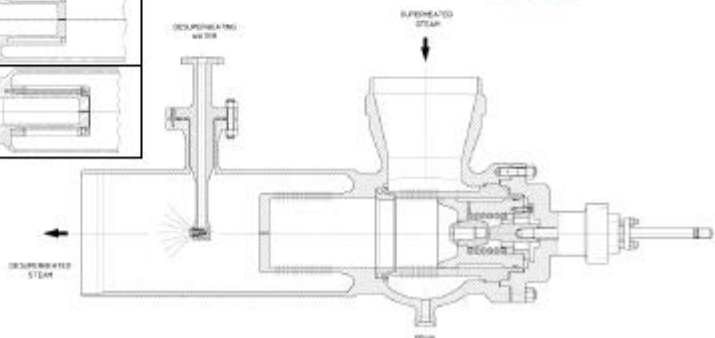

SECTIONAL DRAWINGS

**Flanged Body – Bonnet connection
ANSI 150 ÷ 600**

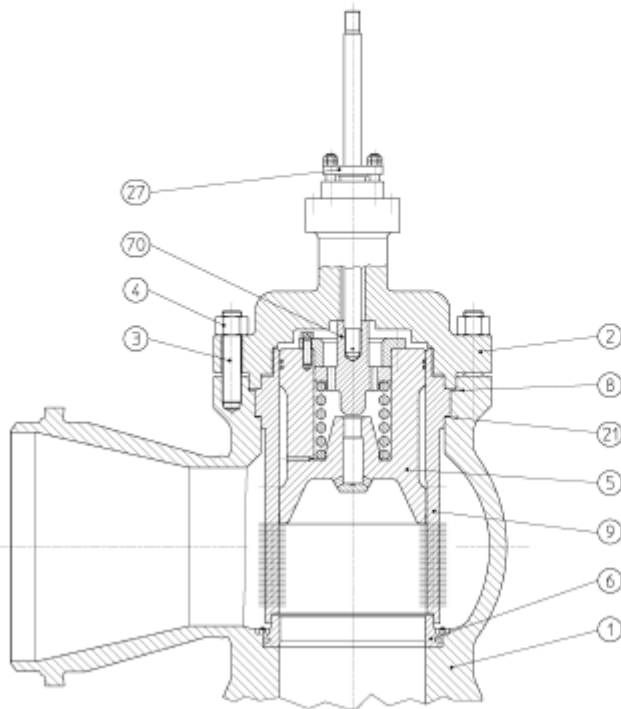

ITEM	PART NAME
1	BODY
2	BONNET
3	STUD
4	NUT
5	PLUG
6	SEAT
8	GASKET
9	CAGE
21	GASKET
27	PACKING BOX

**Pressure Seal – Bonnet connection
ANSI 900 ÷ 2500**

ITEM	PART NAME
1	BODY
2	BONNET
5	PLUG
6	SEAT
9	CAGE
13	SEAL RING
16	FLANGE
17	RETAINING RING
19	RING NUT
20	SPACER
27	PACKING BOX
34	STOP RING
35	STUD
36	NUT
38	SCREW
39	NUT

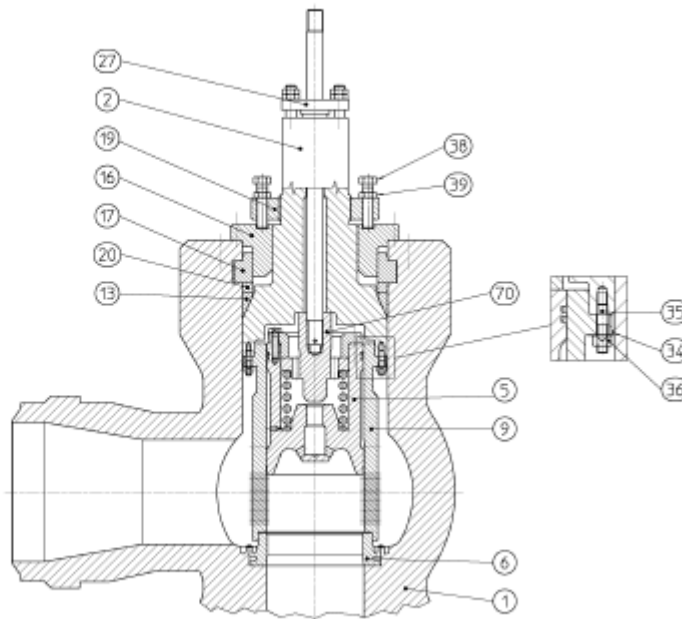

Balanced Plug with Pilot
ANSI 150 ÷ 2500

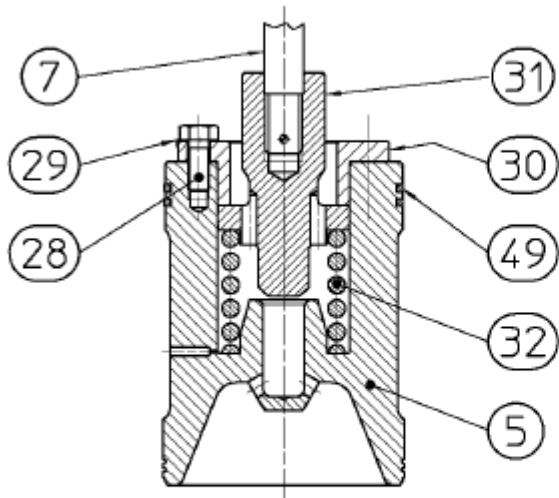

ITEM	PART NAME
5	PLUG
7	STEM
28	SCREW
29	STOP RING
30	FLANGE
31	PILOT
32	SPRING
49	SEAL RING

GRF – Pure Flexible Graphite Packing
Ratings: ANSI 150 ÷ 2500

ITEM	PART NAME
17	PACKING FLANGE
23	STUD
24	NUT
252	PACKING FOLLOWER
255	PACKING RING
257	END RING
274	INTERMEDIATE RING

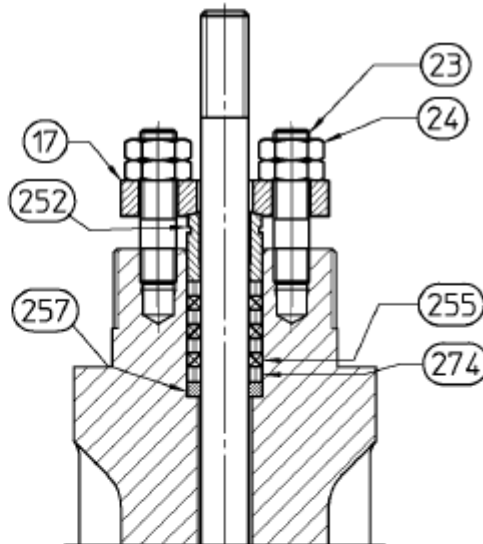

Spare parts

ITEM	PART NAME	STARTUP ⁽¹⁾	STRATEGIC ⁽²⁾
8	GASKET	X	X
13	SEAL RING	X	X
21	GASKET	X	X
50 (5-28-29-30-32-49)	PLUG ASSEMBLY		X
70 (7-31)	STEM-PILOT ASSEMBLY		X
255	PACKING RING	X	
274	INTERMEDIATE RING	X	

⁽¹⁾ commissioning and start-up suggested spare parts
⁽²⁾ two years suggested spare parts

MATERIALS OF CONSTRUCTION

ITEM	PART NAME	Basic Class / Temperature range		
		A (-29 / +427 °C)	D (-29 / +566 °C)	V (-29 / +593°C)
1	BODY	SA 105 / SA 350 LF2 ⁽¹⁾	SA182 F22 Cl.3	SA 182 F91
2	BONNET			
3	STUD	SA 193 B7	SA 479 XM-19	
4	NUT	SA 194 Gr.4	SA 194 Gr.8	
5	PLUG	SA 182 F6NM Nitrided		
6	SEAT	A182 F6NM + Seat Joint CoCr-A Hard Facing		
8	GASKET	AISI 321+GRAPHITE		
9	CAGE	A 351 CA6NM Nitrided		
12	PIN	A 479 316		
13	SEAL RING	A 479 316		
14	GASKET	AISI 321+GRAPHITE		
15	ADAPTER	SA 105 / SA 350 LF2	SA182 F22 Cl.3	SA 182 F91
16	FLANGE	SA182 F22 Cl.3		
17	RETAINING RING	A 182 F91 Nitrided		
19	RING NUT	A 182 F6NM Nitrided		
20	SPACER	A 182 F91		
21	GASKET	AISI 321+GRAPHITE		
25	PLATE	A 479 304		
26	SCREW	A2-70 EN ISO 3506		
27	PACKING	SEE PACKING SUB-CLASS		
28	SCREW	A2-70 EN ISO 3506		
29	STOP WASHER	A 479 304 ANNEALED		
30	FLANGE	A182 F6NM HARDENED 240-300 HB		
32	SPRING	INCONEL X-750 T.T.T.		
34	STOP WASHER	A 479 304 ANNEALED		
35	STUD	B16 for T ≤ 575 °C - XM19 > 575 °C		
36	NUT	SA 194 Gr.8		
38	SCREW	A2-70 EN ISO 3506		
39	NUT	SA 194 Gr.8		
49	SEAL	A182 F6NM HARDENED 240-300 HB		
70	STEM + PILOT ASSEMBLY	A 276 XM19 + A 182 F6NM Nitrided		

ITEM	PART NAME	MATERIAL
17	PACKING FLANGE	AISI 316
23	STUD	AISI 304
24	NUT	AISI 304
252	PACKING FOLLOWER	AISI 316
255	PACKING RING	Flexible Graphite
257	END RING	AISI 316
274	INTERMEDIATE RING	Pure Graphite

⁽¹⁾ only for flanged body-bonnet connection

C_v TABLES

Port		Cv end	C.F. end	Max valve Cv with silencer - gpm					
inc.	mm	gpm	%	Linear Characteristic			Modified Linear Characteristic		
				1 stage	2 stages	3 stages	1 stage	2 stages	3 stages
2"	65.5	0.88	33	78	100	105	70	85	88
3"	83.5	1.3	29	145	170	175	130	145	150
4"	95.5	1.9	32	175	195	205	160	170	180
5"	112.5	2.5	25	260	280	300	235	250	260
6"	127.5	3.3	21	355	390	410	330	355	370
7"	146.5	4.2	24	450	455	485	400	405	425
8"	162.5	5	22	570	575	605	525	530	555
9"	186.5	6.4	24	720	705	715	645	635	640
		6.4	19	780	765	780	725	710	720
10"	216.5	8.5	20	1 000	960	1 000	905	875	915
		8.5	15	1 100	1 050	1 150	1 050	1 000	1 050
12"	244.5	10	21	1 200	1 150	1 150	1 100	1 050	1 050
		10	16	1 400	1 300	1 300	1 300	1 200	1 250
13"	266.5	13	17	1 600	1 400	1 400	1 450	1 300	1 300
		13	11	1 800	1 500	1 550	1 700	1 450	1 500
14"	294.5	15	18	1 950	1 650	1 650	1 800	1 550	1 500
		15	12	2 250	1 850	1 800	2 150	1 750	1 700
15"	324.5	18	15	2 400	1 950	1 900	2 250	1 850	1 850
		18	11	2 650	2 050	2 050	2 500	2 000	1 950
16"	344.5	20	17	2 700	2 150	2 050	2 450	2 000	1 950
		20	12	2 950	2 250	2 200	2 800	2 200	2 100
17"	364.5	23	14	3 100	2 500	2 400	2 900	2 400	2 300
		23	10	3 300	2 600	2 450	3 200	2 550	2 400
18"	390.5	25	11	3 800	2 900	2 700	3 600	2 800	2 650
19"	416.5	29	11	4 250	3 250	3 000	4 050	3 200	2 950
20"	443.5	33	11	4 750	3 650	3 300	4 500	3 550	3 200
22"	484.0	39	11	5 550	4 200	3 750	5 200	4 050	3 650
24"	524.5	46	11	6 400	4 800	4 400	5 900	4 600	4 250

(1) The minimum controllable Cv Value must be at least 30% above "Cv end and C.F." to take in account for Cv nominal tolerances.
 (3)

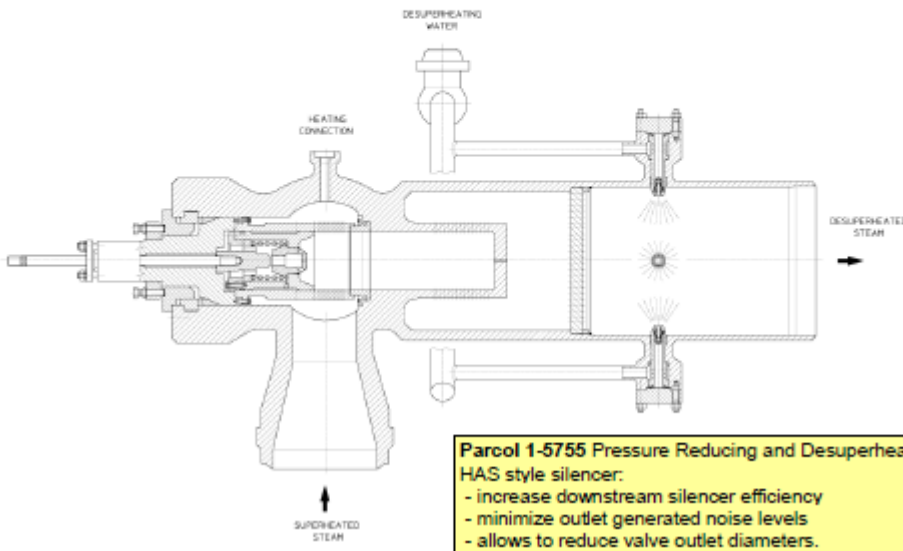



Parcol single effect diaphragm pneumatic actuator 1-X-252 D63 equipped with hydraulic manual operator, with speed regulating additional function.

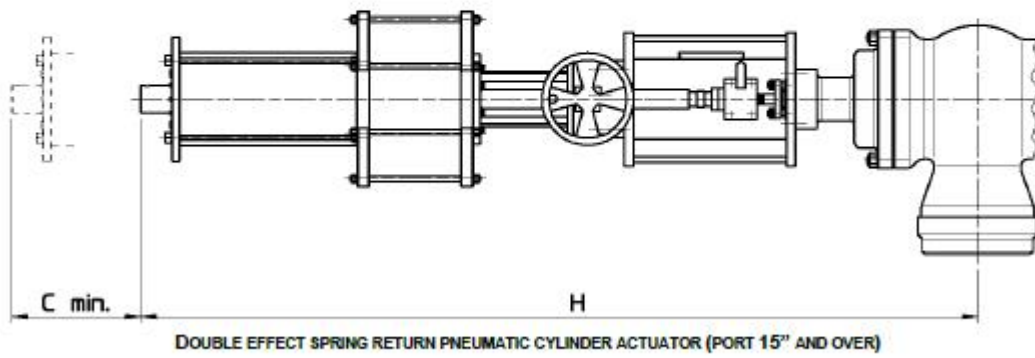

H.P. to I.P. valve 1-5746

- Inlet: DN 8" ANSI 2500 BW
- Outlet: DN 14" ANSI 600 BW
- Port: 6"

Body material: SA 182 F91

Desuperheater: Parcol Spraysat 1-4442

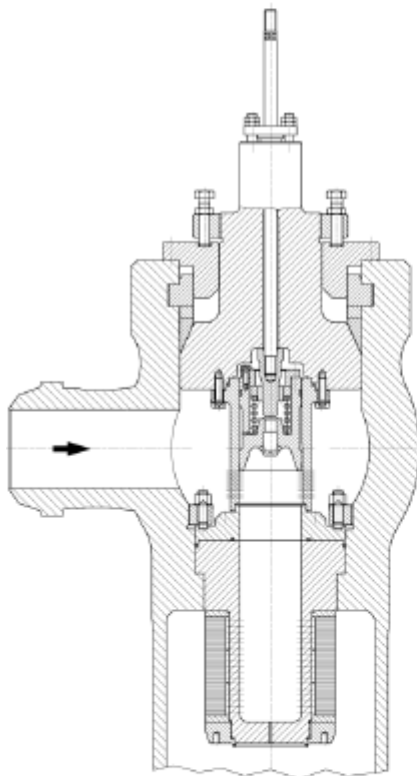
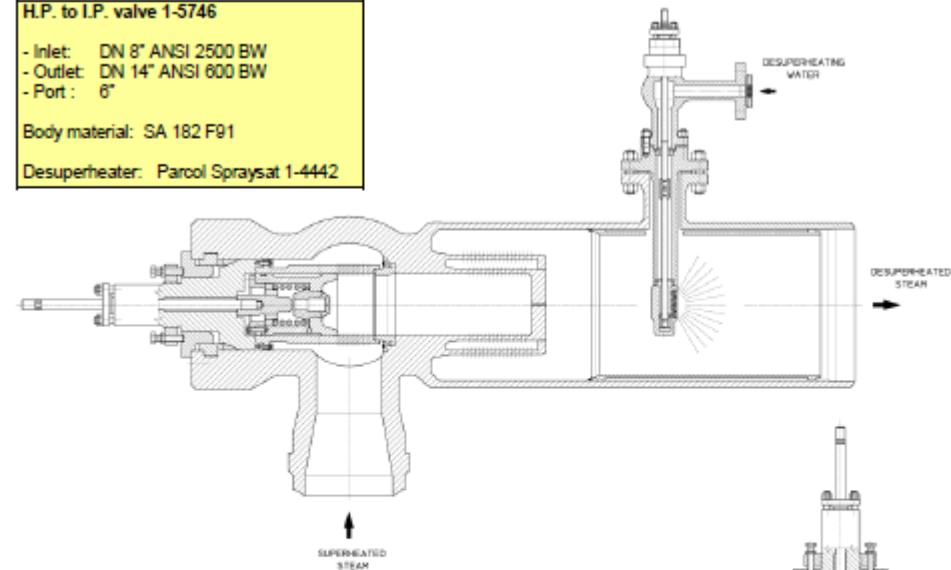

Parcol 1-5760QL pressure reducing valve with quick change seat and Limiphon silencer, suitable for high differential pressure services when very low noise levels are required.

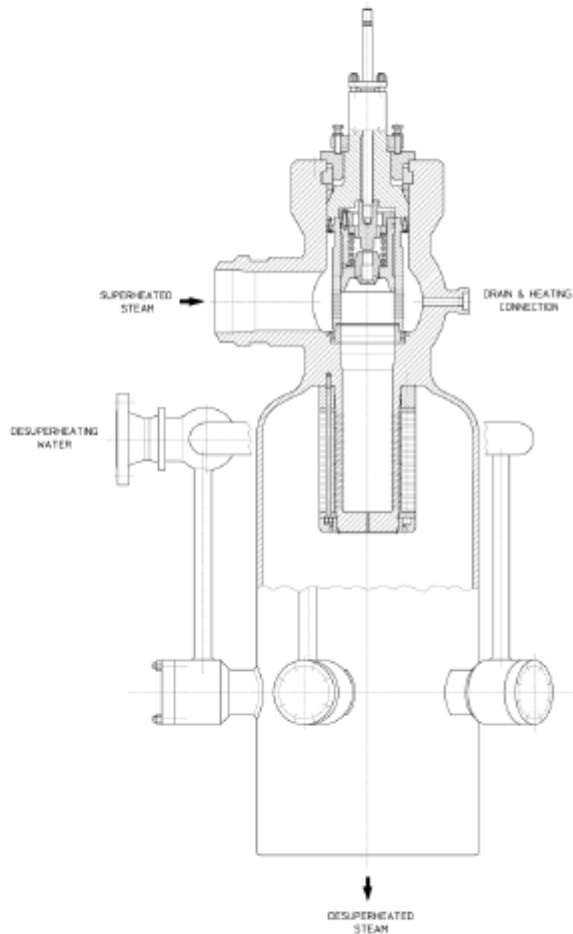

H.P. to condenser bypass valve 1-5765

- Inlet: DN 8" ANSI 2500 BW
- Outlet: DN 24" ANSI 300 BW
- Port: 7"

Body material: SA182 F91

Desuperheater: Parcol LVM 3-4121

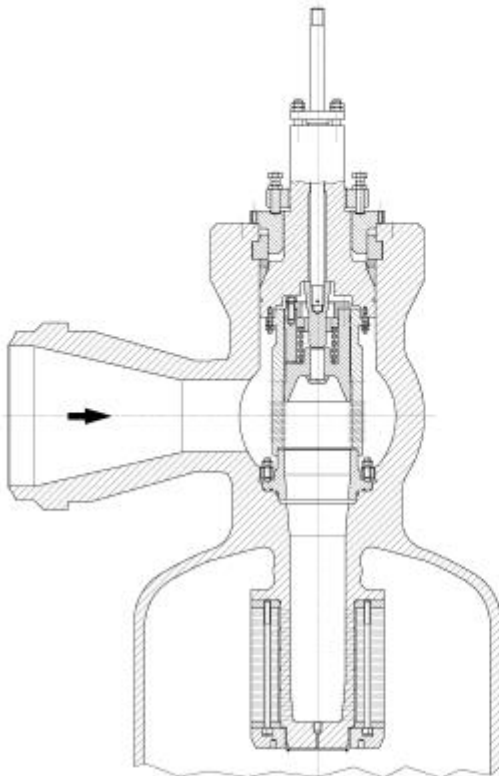

Parcol 1-5740QL pressure reducing valve with quick change seat, suitable for high differential pressure services when very low noise levels are required.



Parcol 1-5745 designed for by-pass service in hypercritical boiler power plant with upstream steam temperature 612°C and upstream pressure 75 bar.

- Inlet: DN 14" ANSI 1500 BW
- Outlet: DN 28" ANSI 300 BW
- Port: 9"

Body material: SA182 F91 + F92

Desuperheater: Parcol LVM 3-4122

HYDRAULIC CONTROL SYSTEM

Parcol 1-5700 Pressure Reducing and Desuperheating Stations can be supplied equipped with Hydraulic Actuators and complete Hydraulic Control System (HCS).

Three standard HCS configurations are available:

Advanced system composed by:

- 1 Hydraulic Power Unit (HPU) with oil pumps, level and pressure switches, accumulator for pump switchover and Motor Control Cabinet (MCC) for pumps drive and protection;
- 1 Hydraulic Control Panel (HCP) for each valve including solenoid valves for emergency actions and proportional valve for valve positioning;
- 1 Electric Control Panel (ECC) including PLC and relays for HPU and valves management;
- 1 Hydraulic Cylinder for each valve including position transmitter in case of control valves and limit switches.

Intermediate system composed by:

- 1 Hydraulic Power Unit (HPU) with oil pumps, level and pressure switches, accumulator for pump switchover and Motor Control Cabinet (MCC) for pumps drive / protection;
- 1 Hydraulic Control Panel (HCP) for each by-pass line (Pressure Reducing Control Valve, Desuperheating Control Valve and Desuperheating Isolation Valve) including solenoid valves for emergency actions and proportional valves for valve positioning;
- 1 Electric Control Panel (ECC) including PLC and relays for HPU management and digital cards for valves positioning;
- 1 Hydraulic Cylinder for each valve including position transmitter in case of control valves and limit switches.

Basic system composed by:

- 1 Hydraulic Power Unit (HPU) managed by DCS, with oil pumps, level and pressure switches, accumulator for pump switchover including solenoid valves for valve fast actions and electric switchboxes for valves management;
- 1 Hydraulic Cylinder for each valve including solenoid valves for emergency actions, closed loop proportional valve and position transmitter in case of control valves and limit switches.

For all systems safety function is ensured also on power failure condition thanks to hydraulic accumulators.

Please refer to Hydraulic Control Systems bulletins for further information.



Parcol 1-5700 Pressure Reduction and Desuperheating Stations (PRDS) with desuperheating water control valves for HP bypass service, equipped with Hydraulic Actuators and complete Hydraulic Control System (HCS).

HYDROSTATIC PRESSURE TEST DEVICES

For valves with different upstream-downstream design conditions, upstream section can be hydrostatically tested up to 250 bar without any special device by closing valve plug.

For higher test pressures or when downstream section must be tested separately from upstream section, pressure test devices can be supplied.

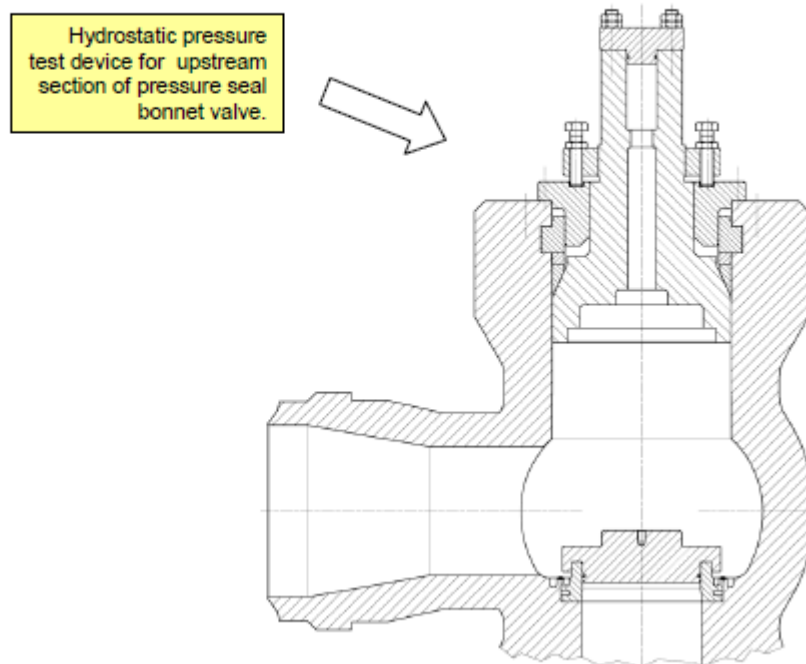
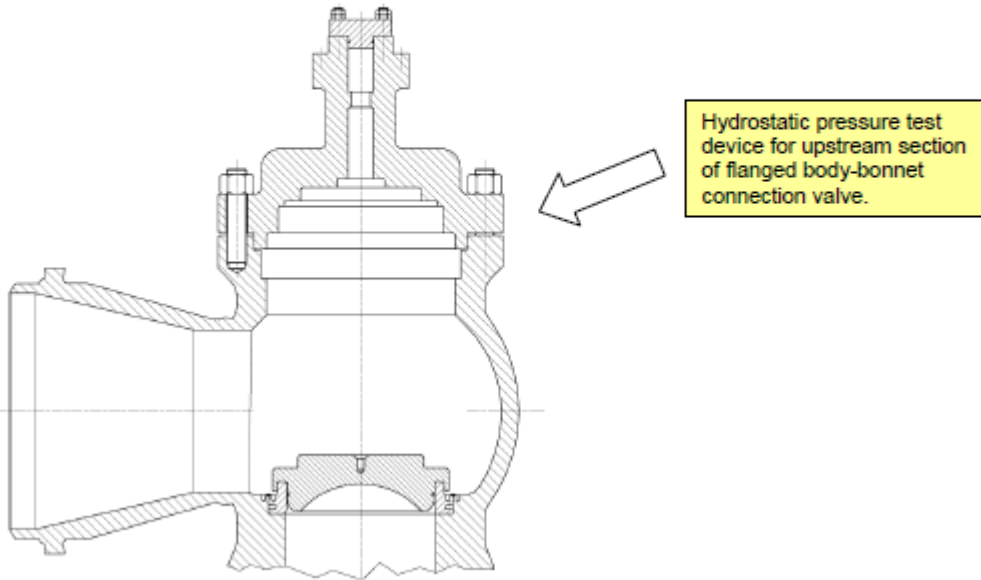

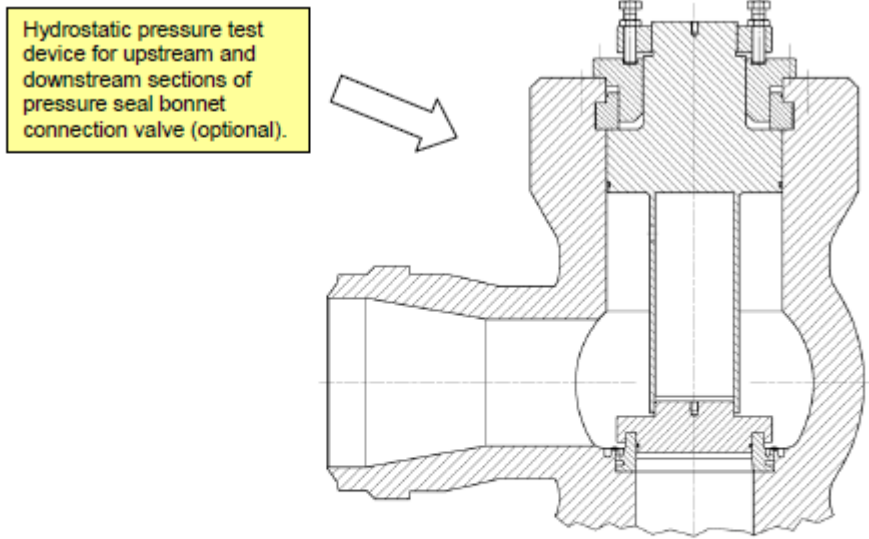
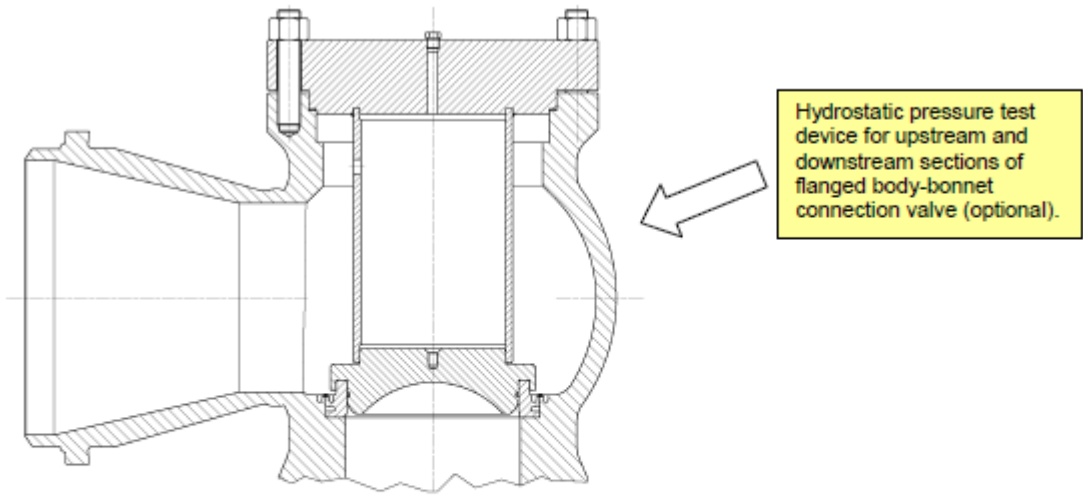

BLOWING DEVICES

Valve seat of 1-5700 PRDS is self-protected by the micro-drilled cage, however line cleaning before valve operation is strongly recommended to avoid trim clogging and internal parts damage.

Blowing devices, typically with "blow out" function, can be supplied on request to perform line cleaning before put valves in service.

Blow through devices are usually supplied only when quick change seat and silencer are provided.

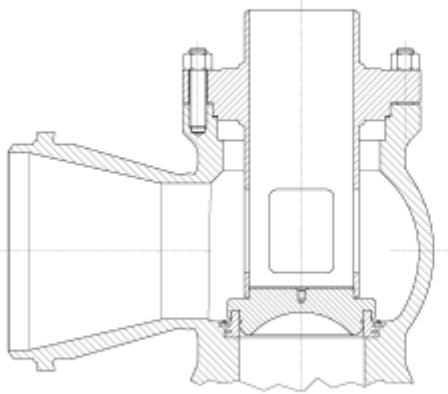

Blow Out device for flanged body-bonnet connection valve.



Blow Out device for pressure seal bonnet valve.

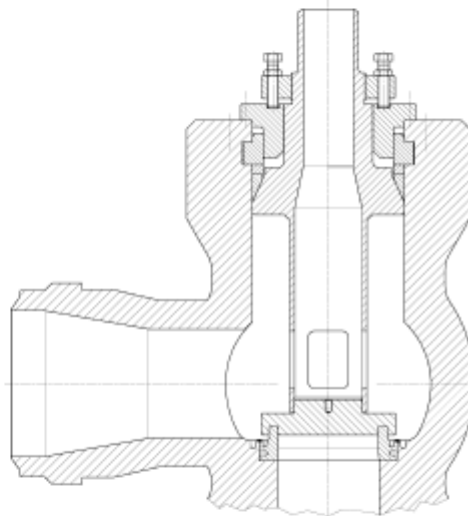

Blow Through device for pressure seal bonnet valve.

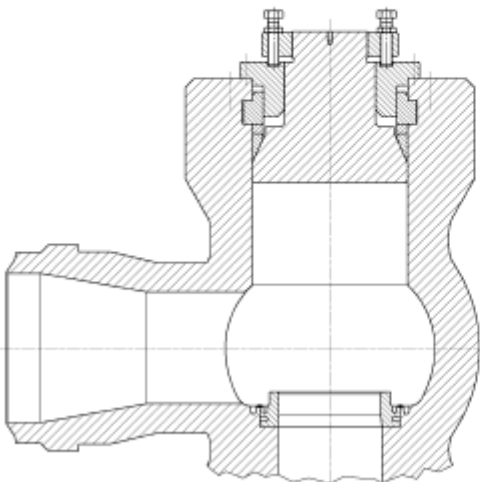

SPECIAL MAINTENANCE TOOLS

1-5700 PRDS are often installed with horizontal actuator axis. For such a installation special tools can be supplied, on request, to simplify disassembly and re-assembly operations.

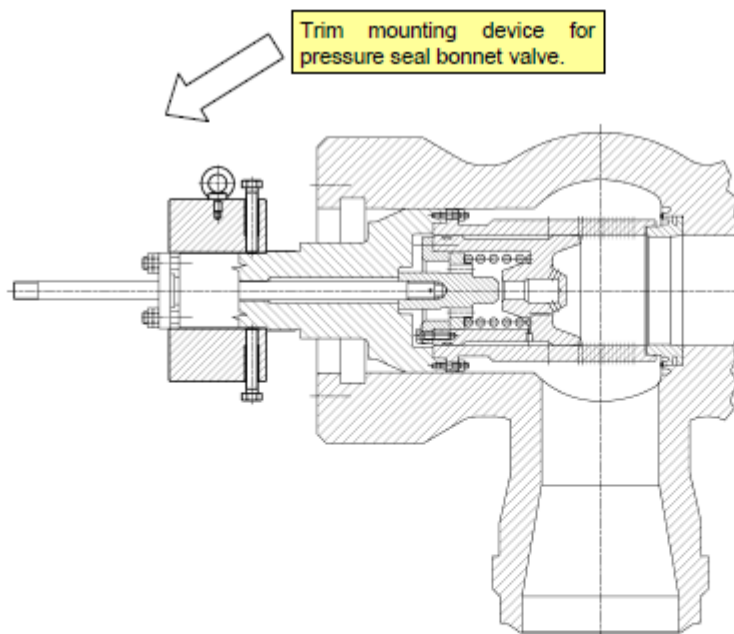
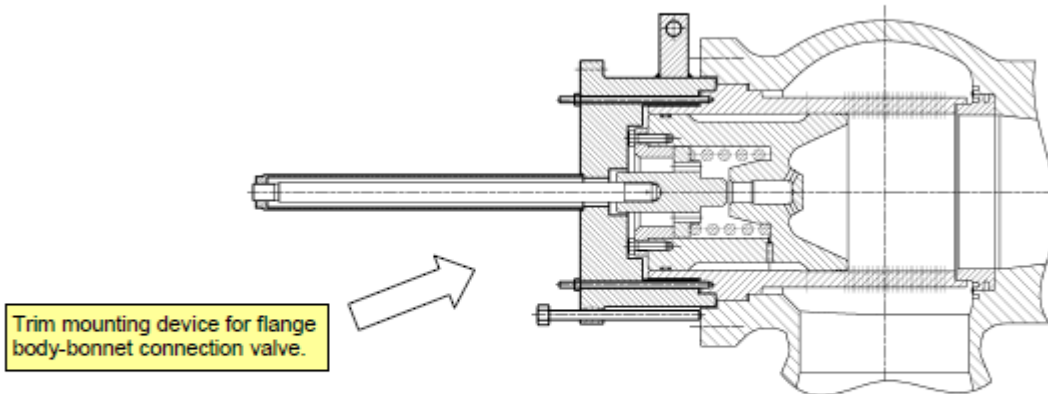

DTC - DUMP TUBES TO CONDENSER

Dump tubes are usually installed in by-pass systems to condenser downstream PRDS to produce suitable backpressure in order to reduce outlet valve and piping diameter optimizing global cost of installation. In addition dump tubes optimize PRDS performances through last steam expansion that produce complete evaporation of residual injected desuperheating water improving homogeneous distribution of temperature inside steam condenser or into steam duct to air cooled condenser. Dump tubes are specially designed to fully comply with specific application requirements in order to minimize dimensions and costs in the respect of noise requirements.

Typical dump tube construction for conventional water cooled condenser.

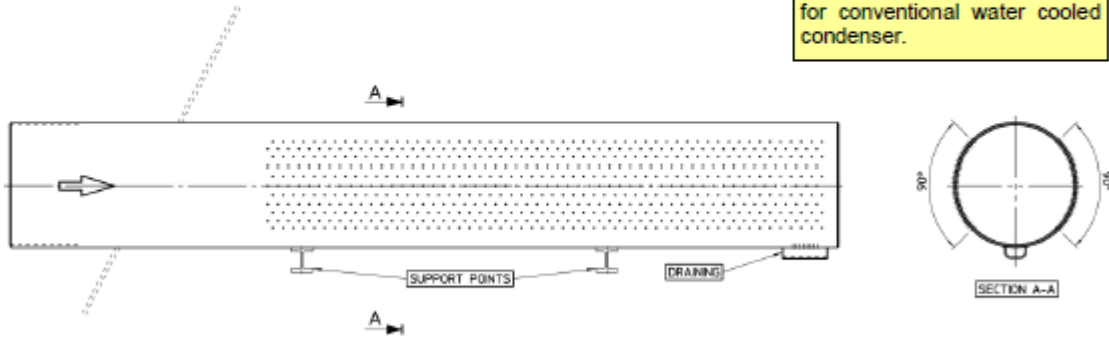

Typical multi-step low noise dump tube construction for air cooled condenser. Dump tube discharges into the steam duct to condenser.

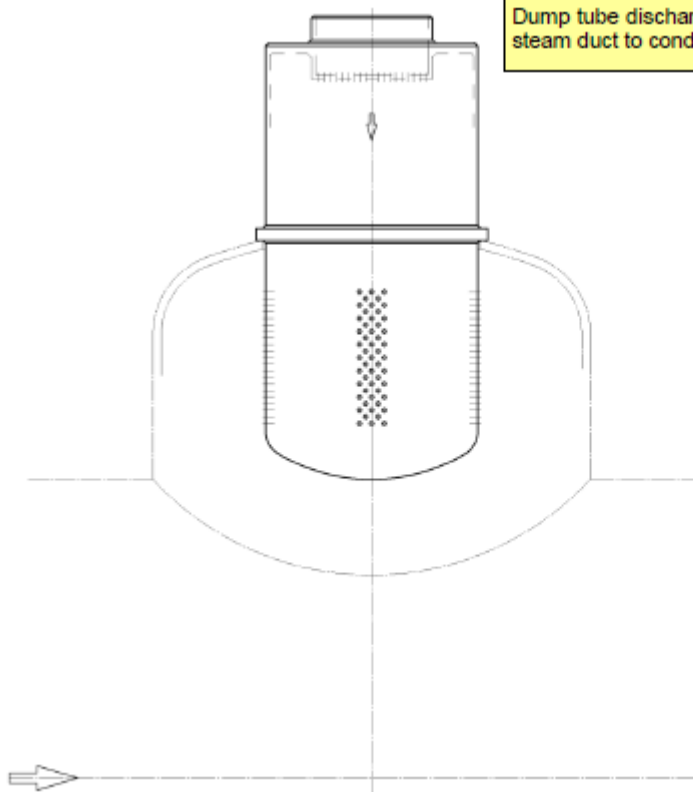



MP bypass, Dump Tube to air cooled condenser

- Inlet connection: DN 36"
- Steam duct connection: 4500 mm

Body material: CrMo steel

1-4470 SERIES – HIGH TEMPERATURE HIGH PRESSURE CONTROL VALVES

Parcol 1-4470 Series control valves are designed and manufactured simlary to PRDS 1-5700 pressure reducing valves except for desuperheating system not provided (for further infomation see 1-4470 HTHP bulletin).

STEAM BYPASS STOP VALVE SERVICE

When compact piping layout is required, Parcol 1-4473 (without silencer), flow to close pilot balanced plug control valves, can be supplied with Stop Valve function installed immediately upstream 1-5700 PRDS.

Flow capacities Cv - gpm

Port		body		stroke	Cv
inc.	mm	mm	mm	mm	gpm
2"	85.5	73	45		160
3"	83.5	93	60		270
4"	95.5	106	60		335
5"	112.5	124	78		475
6"	127.5	140	100		625
7"	146.5	162	100		790
8"	162.5	178	120		990
9"	186.5	206	120		1 250
10"	216.5	238	150		1 730
12"	244.5	270	150		2 160
13"	266.5	294	200		2 690
14"	294.5	324	200		3 200
15"	324.5	358	250		3 980
16"	344.5	380	250		4 430
17"	364.5	400	300		5 000
18"	390.5	430	400		5 900
19"	416.5	480	400		6 600
20"	443.5	485	400		7 500
22"	484.0	535	400		8 800
24"	524.5	575	400		10 300

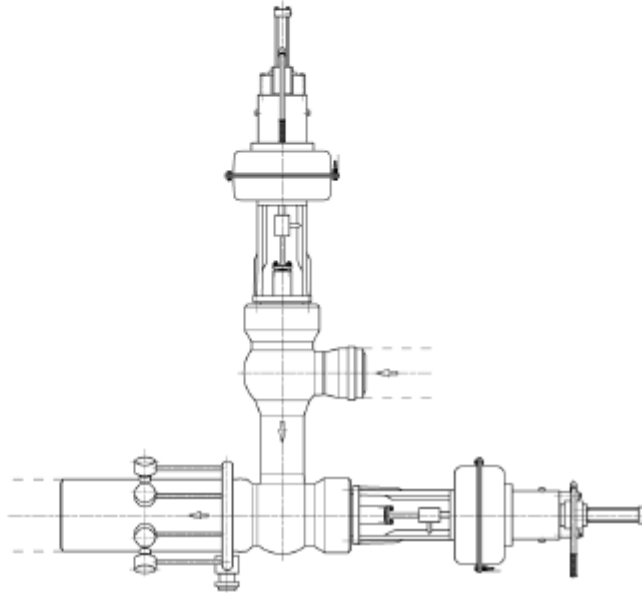

Differential pressure limit x_T : 0.72

Parcol 1-4473 Stop Valve combined with 1-5700 PRDS for On-Off Service.